

# KARATA<sup>®</sup>

OFTEN IMITATED NEVER DUPLICATED

#34



[www.karata.com](http://www.karata.com)

# **The KARATA Timeline**

## **Forging the path of Innovation**

**1972**

***First electric-start belt drive for Sportsters***

**1974**

***First electric start Big Twin primary belt drive***

**1981**

***First secondary belt drive for Big Twins, stock and custom***

**1986**

***First FXR primary and secondary belt drives featuring a 1.500" rear belt***

**1993**

***First commercially produced 3" open electric start belt drive***

***First commercially produced 4" open electric start belt drive***

**1994**

***First and only one piece 6061-T6 billet motor plate***

**1998**

***First commercially produces outboard bearing support systems for belt drives***

***First commercially produced 5" open electric start belt drive***

**2003**

***Piranha Klutches are introduced***

***First commercially produced Extended Center Distance open electric start belt drive***

**2004**

***First commercially produced Extended Center Distance right side drive motor plates***

***First commercially produced right side drive motor plates***

**2005**

***First commercially produced Dyna right side drive primary belt drives***

***First commercially produced right side drive primary belt drives specifically designed for Big Dog motorcycles using Baker Drivetrain's new DSSC system***



# TABLE OF CONTENTS

<b>INTIMIDATOR SERIES PRIMARY BELT DRIVES</b>	<b>1-01 - 1-32</b>
Big Dog	1-06 - 1-09
Softail	1-10 - 1-11
Softail Extended Center Distance, XCD	1-12 - 1-13
Softail PM/PYO, Dyna Ness Y2K	1-14 - 1-15
Dyna	1-16 - 1-17
FXR	1-18 - 1-19
Road King/FLT	1-20 - 1-21
Shovelhead	1-22 - 1-25
Panhead	1-26 - 1-27
Knucklehead	1-28 - 1-29
Kick Start	1-30 - 1-31
<b>OUTBOARD BEARING SUPPORT SYSTEMS</b>	<b>2-01 - 2-10</b>
<b>PIRANHA KLUTCHES</b>	<b>3-01 - 3-04</b>
<b>INTIMIDATOR SERIES BILLET ALUMINUM MOTOR PLATES &amp; BILLET ALUMINUM ACCESSORIES</b>	<b>4-01 - 4-08</b>
<b>ENCLOSED &amp; OPEN PRIMARY BELT DRIVES</b>	<b>5-01 - 5-08</b>
Softail	5-02 - 5-03
Shovelhead FX Sturgis Repair Assembly	5-03
FXR/FLT/Road King	5-04
Evolution FX	5-05
Shovelhead	5-05
Panhead	5-05
Knucklehead	5-05
Sportster	5-06
<b>REAR BELT DRIVES</b>	<b>6-01 - 6-04</b>
<b>REPLACEMENT BELTS FOR PRIMARY &amp; REAR BELT DRIVES</b>	<b>7-01 - 7-04</b>
<b>REPLACEMENT ENGINE &amp; CLUTCH BASKET PULLEYS, TRANSMISSION &amp; REAR WHEEL PULLEYS</b>	<b>8-01 - 8-06</b>
<b>REPLACEMENT COMPONENTS</b>	<b>9-01 - 9-06</b>
<b>TERMS &amp; CONDITIONS OF SALE</b>	<b>A-01 - A-02</b>

BAD BOY, BUELL, CONVERTIBLE, DEUCE, DUO GLIDE, DYNA, DYNA GLIDE, DYNA WIDE GLIDE, ELECTRA GLIDE, EVOLUTION, FAT BOB, FAT BOY, FAT HEAD, HARLEY, HARLEY-DAVIDSON, H-D, HERITAGE SPRINGER, HYDRA GLIDE, HUGGER, LIGHTNING, LOW RIDER, NIGHT TRAIN, ROAD GLIDE, ROAD KING/FLT, SCREAMIN EAGLE, SOFTAIL, SPORTSTER, SPRINGER, SUPER GLIDE, T-SPORT, THUNDERBOLT, TOUR-PAK, TWIN CAM, TWIN CAM 88A, TWIN CAM 88B, ULTRA CLASSIC, V-FIRE III, V-ROD AND WIDE GLIDE ARE REGISTERED TRADEMARKS OF THE HARLEY-DAVIDSON MOTOR COMPANY, INC., MILWAUKEE, WI, U.S.A.

HARLEY-DAVIDSON® AND BUELL® MOTORCYCLE MODEL DESIGNATIONS ARE UTILIZED IN THIS CATALOG FOR REFERENCE ONLY:

EL, FL, FLH, FLHC, FLHF, FLHR, FLHRCI, FLHRI, FLHRSEI, FLHS, FLHT, FLHTC, FLHTCI, FLHTCU, FLHTCUI, FLHTC, ULTRA, FLHX, FLST, FLSTC, FLSTI, FLSTF, FLSTFI, FLSTS, FLSTSI, FLT, FLTC, FLTCUI, FLTC ULTRA, FLTR, FLTRI, FXB, FXD, FXDB, FXDG, FXDL, FXDS-CON, FXDWG, FXDX, FXDXT, FXE, FXEF, FXLR, FXR, FXRC, FXRDG, FXRS, FXRSE, FXRS-SP, FXRT, FXS, FXSB, FXST, FXSTI, FXSTB, FXSTSI, FXWG, K, KH, WL, WLA, XL, XK883R, XL 1200C, XL 1200S, XLCH, XLCR, XLH, XLH 883, XLH 883C, XLH 883 HUGGER, XLH 1100, XLH 1200, XLR, XLS, XLT, XR, M2, X1, S1, S2, S2T, S3, S3T, FIREBOLT XB9R, VRSCA AND BLAST.



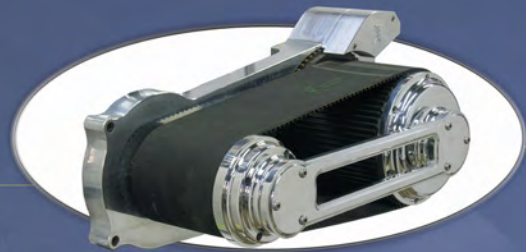

# *INTIMIDATOR SERIES*

## **PRIMARY BELT DRIVES**



# WHY CHOOSE INTIMIDATOR®?

**KARATA ENTERPRISES** is a company with over 33 years of experience in the design, development and manufacture of premiere-quality belt drive systems. As one of the originators of the primary belt drive for motorcycles, **KARATA ENTERPRISES** has built our reputation on proven quality, serviceability and precision manufacturing. Although several of our competitors have copied many of our ground-breaking innovations, none of them can claim the long list and history of innovations that were created by **KARATA ENTERPRISES**. We are often imitated, but NEVER duplicated. Do not be fooled, you can buy quality once, or pay the price for inferior components over and over.

What makes Karata **INTIMIDATOR** series primary belt drives the best? Our commitment to quality. We understand that the master bike builder, mechanic and rider will settle for no less than the best when it comes to their motorcycles. This is why the level of quality found in every **INTIMIDATOR SERIES** primary belt drive is unmatched by any of our competitors.



### MOTOR PLATES:

Every **INTIMIDATOR SERIES** motor plate is CNC machined from a **SOLID** piece of 6061 aluminum billet. We offer offset motor plates for specific applications that range from .250" to 2.00". Each offset is machined as part of the plate, eliminating the need for primary spacers which are useful but not capable of adding any strength. Is this more costly? Absolutely, but when compared to other manufacturers' motor plates that are bolted-together from several pieces or made from a cast plate that is machined to look like billet, the choice becomes clear: The **STRONGEST** motor plate money can buy is the **KARATA INTIMIDATOR**.. And strength is key to ensure the proper function of any belt drive, whether it's on a factory street bike or on a high-horsepower radical custom.

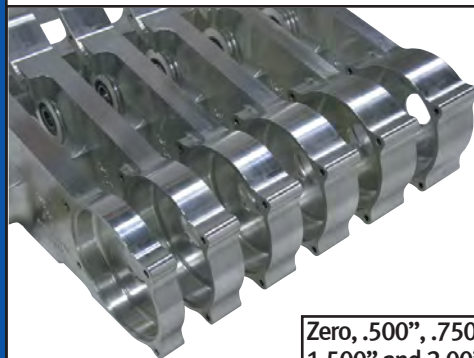

Zero, .500", .750", 1.000", 1.500" and 2.00" offset motor plates shown here.

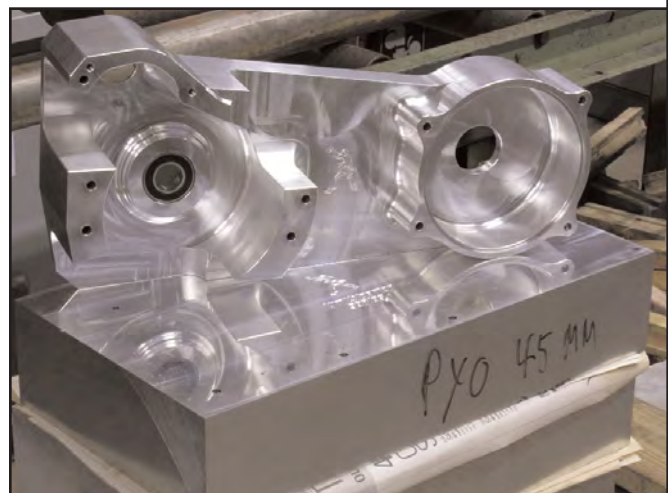

Even the massive 45mm offset motor plate used with Paul Yaffe Twin Cam wide tire conversions is carved from a 130-pound slab of aluminum over 4-inches thick.

Intimidator  
Primary  
Belt Drives

Outboard  
Bearing  
Supports

Piranha  
Clutches

Intimidator  
Motor Plates  
& Accessories

Enclosed &  
Open Primary  
Belt Drives

Rear Belt  
Drives

Replacement  
Primary &  
Rear Belts

Replacement  
Pulleys

Replacement  
Components

Terms &  
Conditions  
Of Sale



# INTIMIDATOR SERIES PRIMARY BELT DRIVES

## PULLEYS:

Our pulleys are machined to specific tolerances. The teeth are then gear-cut to proprietary dimensions as called out by our belt manufacturers, Gates and Goodyear. This ensures optimal wrap and belt release in addition to providing cool, quiet operation and long, dependable service.

**KARATA'S** aluminum pulleys, for **INTIMIDATOR SERIES** belt drives and standard belt drives are hard anodized in house to 62 Rockwell hardness with an exclusive Alcoa/Martin process. This adds durability and an attractive finish that complements any motorcycle's appearance.



## BEARING SUPPORT SYSTEMS

**KARATA'S** outboard bearing support systems are sold as part of all 5" **INTIMIDATOR SERIES** primary belt drives. They are also offered as optional accessories for the 3" and 4" **INTIMIDATOR** belt drives and can be retrofitted to all **INTIMIDATOR** belt drives ever made.

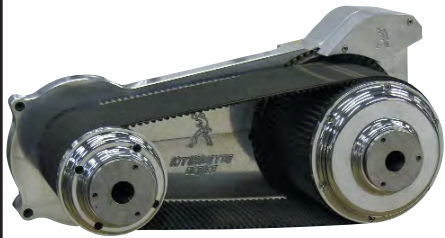

The design is simple and strong. Massive 3" bearings are housed in precision-machined, polished pulley covers with steel carriers that bolt to each pulley and are connected by a support plate. These carriers are located exactly on center of each shaft and the support plate maintains the exact center distance of the motor plate. By tying the pulleys together in this manner, pulley and/or shaft movement is absolutely eliminated.

The design is simple and strong. Massive 3" bearings are housed in precision-machined, polished pulley covers with steel carriers



With over 30 different support plates and the option to run no cover, a partial cover or a full cover, the **KARATA** design is simple and stylish. There is simply no way either pulley can move.

## BELTS:

All **INTIMIDATOR SERIES** primary belt drives use 8mm Goodyear STPD Kevlar belts. For the tough requirements of the **INTIMIDATOR** belt drives, there simply isn't a better belt. **KARATA** has been using Goodyear belts for over 30 years and we stock a complete line of replacement belts in all sizes.



Intimidator  
Primary  
Belt Drives

Outboard  
Bearing  
Supports

Piranha  
Clutches

Intimidator  
Motor Plates  
& Accessories

Enclosed &  
Open Primary  
Belt Drives

Rear Belt  
Drives

Replacement  
Primary &  
Rear Belts

Replacement  
Pulleys

Replacement  
Components

Terms &  
Conditions  
Of Sale

## INTIMIDATOR SERIES PRIMARY BELT DRIVES

# WHAT YOU GET WITH INTIMIDATOR®

Intimidator  
Primary  
Belt Drives

Outboard  
Bearing  
Supports

Piranha  
Clutches

Intimidator  
Motor Plates  
& Accessories

Enclosed &  
Open Primary  
Belt Drives

Rear Belt  
Drives

Replacement  
Primary &  
Rear Belts

Replacement  
Pulleys

Replacement  
Components

Terms &  
Conditions  
Of Sale



### EVERY INTIMIDATOR SERIES KIT IS COMPLETE

Every **KARATA INTIMIDATOR SERIES** primary belt drive is supplied with all components and necessary mounting hardware and instructions to insure a complete and simple installation.

### WHY CLUTCHES ARE OPTIONAL

As most of the **INTIMIDATOR SERIES** primary belt drives were originally designed to be installed on stock motorcycles, they were, and still are, built to be used with OEM or OEM-replacement high-performance clutches.

Additionally, with the wide selection of after-market clutches available today, we understand that every builder, mechanic and rider has their own preference. Therefore, all **KARATA INTIMIDATOR SERIES** primary belt drives are sold without clutches in order to provide more choice to the builder, mechanic and rider.

For OEM clutch replacement, and for custom motorcycles with high-horsepower engines, **KARATA** offers the **PIRANHA KLUTCH** in two massive configurations.

For complete, detailed information on the **PIRANHA KLUTCH** series, see **SECTION 3**.



### ALL INTIMIDATOR SERIES PRIMARY BELT DRIVES INCLUDE THE FOLLOWING:

- One-piece billet aluminum motor plate with sealed mainshaft bearing, installed
- Billet aluminum jackshaft support
- Billet steel starter jackshaft
- Front pulley with steel retaining ring
- Rear pulley with ring gear and double-row clutch hub bearing, installed
- Goodyear STPD 8mm belt
- Engine shaft nut
- All necessary hardware included
- **5-inch belt drives include an outboard bearing support plate style. For a complete listing of all bearing support plate styles, see Section 2**

### BELTS:

The Goodyear STPD 8mm belt is used on all **INTIMIDATOR SERIES** primary belt drives, in the following belt lengths:

#### 140 & 144-tooth

- Softail & Custom
- Dyna
- FX/FL Swingarm models
- Panhead, electric start and kick
- Knucklehead, electric start and kick

#### 160-tooth

- Extended Center Distance (XCD):

#### 132-tooth

- FXR
- Road King/FLT

# INTIMIDATOR SERIES PRIMARY BELT DRIVES OPTIONS & ACCESSORIES

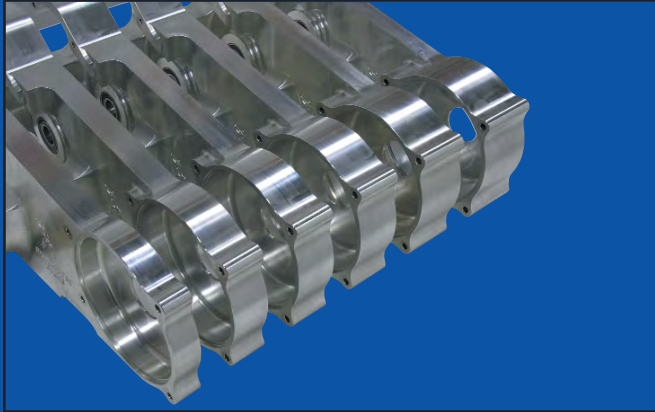

## OFFSET MOTOR PLATES

Many *INTIMIDATOR SERIES* primary belt drives can be ordered with offset motor plates. Each offset is machined into the plate itself, which provides superior strength and versatility. For complete, detailed information on offset motor plates, see **SECTION 4**.

## SOFTAIL & CUSTOM BELT DRIVES

16401, 16404, 16407, 16435

Nine offsets available:

.250", .500", .750", 1.000",  
1.250", 1.437", 1.500", 1.750", 2.000"

## DYNA BELT DRIVES

16446, 16447, 16448  
16437, 16438, 16439

One offset available:

1.00" (engine *and* transmission offset)

## FXR BELT DRIVES

16453, 16454

One offset available:

1.00"

## FX/FL SWINGARM

### 5-SPEED CONVERSION BELT DRIVES

16430, 16431, 16432

Nine offsets available:

.250", .500", .750", 1.000",  
1.250", 1.437", 1.500", 1.750", 2.000"

## FX/FL SWINGARM BELT DRIVES

16464, 16465, 16466, 16467

Five offsets available:

.250", .500", .750", 1.000", 1.250"

## PANHEAD BELT DRIVES

### 5-SPEED CONVERSION BELT DRIVES

16475, 16476, 16477

Three offsets available:

1.000", 1.437", 1.500"



## OUTBOARD BEARING SUPPORT SYSTEMS

*KARATA'S* outboard bearing support systems are offered as optional accessories for 3" and 4" *INTIMIDATOR* belt drives. Any *INTIMIDATOR* belt drive can be outfitted with the outboard bearing support system regardless of manufacture date.

For complete, detailed information on outboard bearing support systems, see **SECTION 2**.

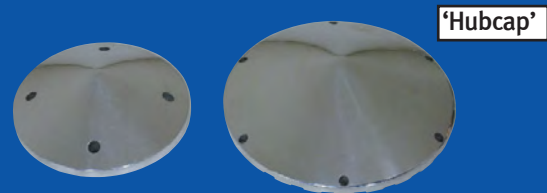

## POLISHED BILLET PULLEY COVERS

*KARATA* offers polished billet pulley covers in two distinctive styles, the 'Hubcap' and the 'Smoothie'. Front and rear pulley covers are sold individually and are designed to fit a large variety of *KARATA* engine and clutch pulleys. For complete, detailed information on polished billet pulley covers, see **SECTION 4**.

'Smoothie'



## SPARES AND REBUILD PARTS

All components used in *KARATA INTIMIDATOR SERIES* belt drives are available separately. Pulleys, motor plates, belts, bearings, bolts, miscellaneous hardware and more, are in stock at all times. For complete, detailed information on spares and rebuild parts, see **SECTION 9**.

Intimidator  
Primary  
Belt Drives

Outboard  
Bearing  
Supports

Piranha  
Clutches

Intimidator  
Motor Plates  
& Accessories

Enclosed &  
Open Primary  
Belt Drives

Rear Belt  
Drives

Replacement  
Primary &  
Rear Belts

Replacement  
Pulleys

Replacement  
Components

Terms &  
Conditions  
Of Sale



**INTRODUCING THE BIG DOG INTIMIDATOR SERIES  
BELT DRIVES WITH ONE-PIECE BILLET MOTOR PLATE**

**INTIMIDATOR SERIES**

BY KARATA

**SOON  
TO BE IMITATED  
BUT NEVER  
DUPLICATED!!!**



Intimidator  
Primary  
Belt Drives

Outboard  
Bearing  
Supports

Piranha  
Klutches

Intimidator  
Motor Plates  
& Accessories

Enclosed &  
Open Primary  
Belt Drives

Rear Belt  
Drives

Replacement  
Primary &  
Rear Belts

Replacement  
Pulleys

Replacement  
Components

Terms &  
Conditions  
Of Sale

# INTIMIDATOR SERIES PRIMARY BELT DRIVES - BIG DOG

## THE KARATA® INTIMIDATOR SERIES®

### DOES IT AGAIN!

The absolute latest and most radical primary belt drive from **KARATA** is the **BIG DOG INTIMIDATOR SERIES**. Built especially for **BIG DOG'S** 250 and 300-series wide tire motorcycles that use Baker Drivetrain's new Drop Starter Slam Clutch (DSSC) system. The result is a bold, new **INTIMIDATOR SERIES** primary belt drive that allows the new Baker DSSC system to be used with an open primary belt drive for true performance and ultimate looks!

With this new addition to the **KARATA** lineup, a new 2.5" belt is the fourth size to be included in the **INTIMIDATOR SERIES** family. Now you can choose between 2.5", 3", 4" and 5".

Two versions of this awesome new **INTIMIDATOR SERIES** primary belt drive are available allowing fitment to **BIG DOG** models with either 250 or 300-series rear tires, specifically: **Chopper, Mastiff** and **Bulldog** models which run a 250-series rear tire, **Pit Bull, Ridgeback** and **K-9** models that run a 300-series rear tire.



Custom builders can now use the new Baker DSSC system in their designs without having to give up the traditional in-your-face styling that only an open primary belt drive can provide. And there's nothing more in-your-face than the new **KARATA BIG DOG INTIMIDATOR SERIES** primary belt drives.

Close-up detail of starter location and hidden ring gear design.

All **BIG DOG INTIMIDATOR SERIES** primary belt drives feature a **ONE-PIECE** billet aluminum motor plate with a show polished finish. A **Piranha Jr. Klutch** is included with all 2.5", 3" and 4" kits, as well as front and rear pulley covers in either 'Smoothie' or 'Hubcap' styles. All 5" kits include the larger **Piranha Klutch** and **KARATA'S** innovative outboard bearing support system (instead of pulley covers). The outboard bearing support system is available separately for 2.5", 3" and 4" kits.



Because **KARATA innovates**, we know it is only a matter of time before our competition **imitates** us. But don't be fooled! Unlike many of our competitors whose belt drive kits come from **overseas**, all **KARATA** belt drive kits and components are **MADE IN THE USA** by **AMERICAN WORKERS**.

**KARATA, OFTEN IMITATED NEVER DUPLICATED!**

Intimidator Primary Belt Drives

Outboard Bearing Supports

Piranha Klutches

Intimidator Motor Plates & Accessories

Enclosed & Open Primary Belt Drives

Rear Belt Drives

Replacement Primary & Rear Belts

Replacement Pulleys

Replacement Components

Terms & Conditions Of Sale



# INTIMIDATOR SERIES PRIMARY BELT DRIVES - BIG DOG

## INTIMIDATOR SERIES

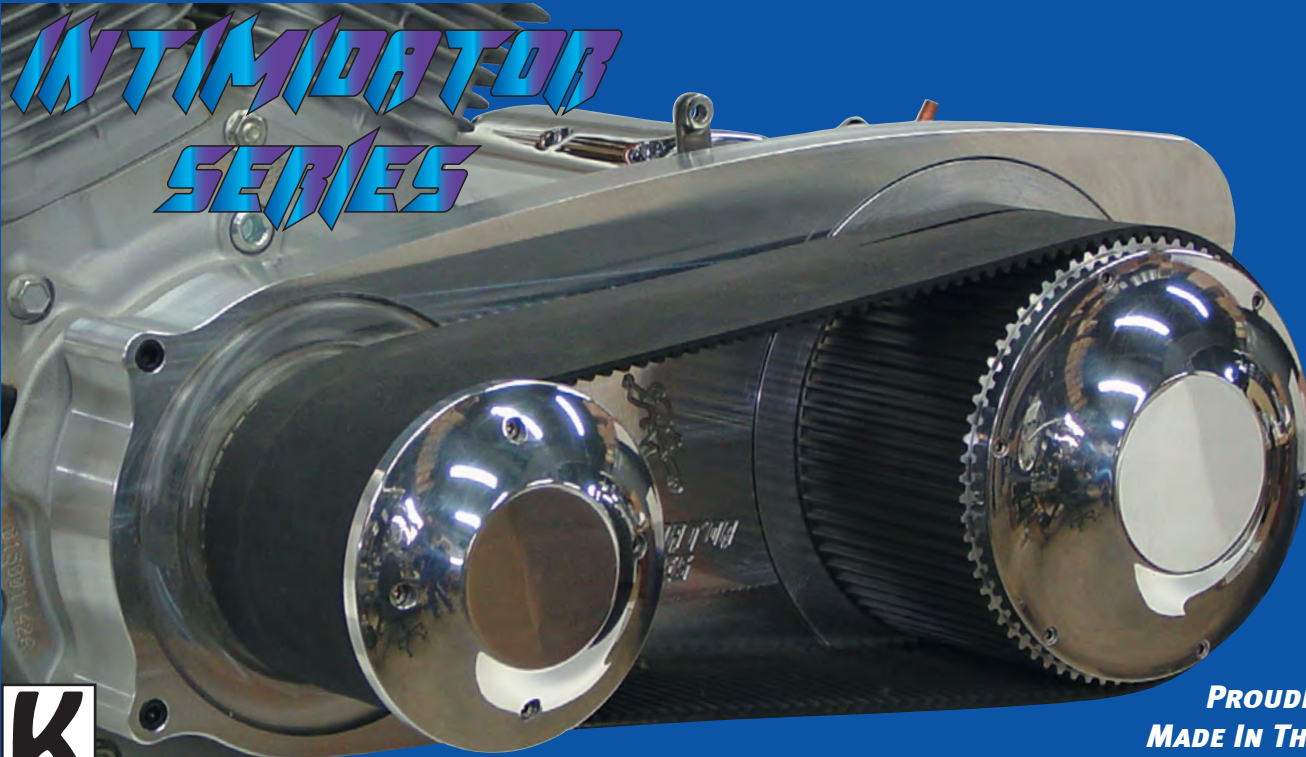

**PROUDLY  
MADE IN THE USA  
BY AMERICAN WORKERS!**

**K**ARATA INNOVATION

## **BIG DOG PRIMARY BELT DRIVES 2.5", 3", 4", 5" WIDTHS RIGHT SIDE DRIVE (RSD)**

### **THE MOST INNOVATIVE INTIMIDATOR SERIES PRIMARY BELT DRIVE YET!!!**

The belt drive that started it all, the awesome **KARATA INTIMIDATOR SERIES** continues to lead the way with the new **BIG DOG INTIMIDATOR SERIES**

### **SIZE, SELECTION & FITMENT**

Available in four sizes, in **Right side Drive ONLY** are the massive 5", beefy 4", traditional 3" and a new, slim 2.5". These belt drives are designed to fit specific Big Dog models from 2005-up that use Baker Drivetrain's new Drop Starter Slam Clutch (DSSC) system with either 250 or 300-series rear tires.

Our new **INTIMIDATOR SERIES** belt drives are designed for 2005-up **BIG DOG Chopper, Mastiff and Bulldog** models with 250-series rear tires and also 2005-up **Pit Bull, Ridgeback and K-9 models** with 300-series rear tires.

For custom motorcycles able to use the Baker Drivetrain Drop Starter Slam Clutch (DSSC) system, this **INTIMIDATOR SERIES** primary belt drive is the only choice.

### **RIGHT SIDE DRIVE APPLICATIONS**

**KARATA** is the first manufacturer in the industry to offer a dedicated family of belt drives specifically for custom motorcycles using Right Side Drive (RSD) transmissions.

Look closely, and you'll see that all **INTIMIDATOR SERIES** primary belt drives that are for RSD applications feature a uniquely-machined motor plate that has no drive belt/chain cut outs. This feature allows for even greater strength and rigidity in addition to setting a new design standard for the industry.

All **BIG DOG INTIMIDATOR SERIES** primary belt drives feature a **ONE-PIECE** billet aluminum motor plate with a show polished finish. A **Piranha Jr. Klutch** is included with all 2.5", 3" and 4" kits, as well as front and rear pulley covers in either 'Smoothie' or 'Hubcap' styles. All 5" kits include the larger **Piranha Klutch** and **KARATA'S** innovative outboard bearing support system (instead of pulley covers). The outboard bearing support system is available separately for 2.5", 3" and 4" kits. See **SECTION 2** for complete details on outboard bearing support systems.

Intimidator  
Primary  
Belt Drives

Outboard  
Bearing  
Supports

Piranha  
Klutches

Intimidator  
Motor Plates  
& Accessories

Enclosed &  
Open Primary  
Belt Drives

Rear Belt  
Drives

Replacement  
Primary &  
Rear Belts

Replacement  
Pulleys

Replacement  
Components

Terms &  
Conditions  
Of Sale

# INTIMIDATOR SERIES PRIMARY BELT DRIVES - BIG DOG

## RIGHT SIDE DRIVE (RSD) KITS

2005-up Big Dog Pit Bull,  
Ridgeback and K-9 models  
with 300-series rear tire

### Right Side Drive

16500	2.5"
16504	3"
16508	4"
16512	5"

2005-up Big Dog Chopper, Mastiff  
and Bulldog models  
with 250-series rear tire

### Right Side Drive

16501	2.5"
16505	3"
16509	4"
16513	5"

**KARATA INTIMIDATOR SERIES**  
Right Side Drive primary belt drive  
kits use dedicated RSD motor  
plates that feature no cut outs on  
the rear of the plate for the drive  
belt or chain. This unique feature  
is another **KARATA INNOVATION**.

**SOON TO BE IMITATED  
BUT NEVER DUPLICATED!**

**INVISIBLE**  
**ELECTRIC START**

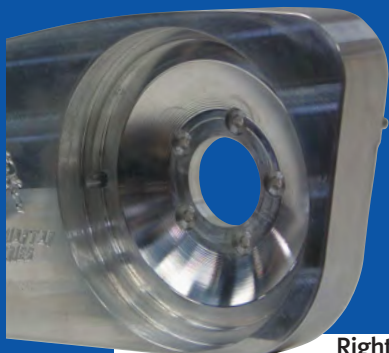

Right Side Drive  
plate has no chain/belt cut outs

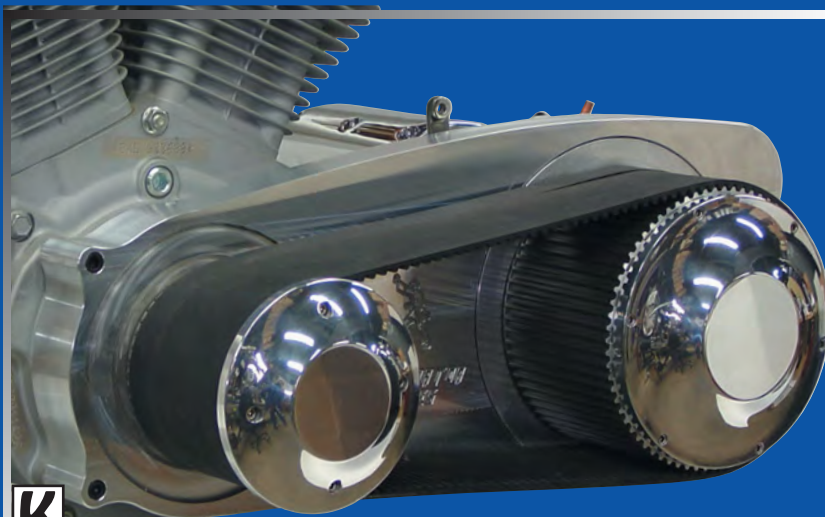

**K**ARATA INNOVATION

16509 INTIMIDATOR 4.0" primary belt drive with  
40088 'Smoothie' front pulley cover and 40090 'Smoothie' rear pulley cover



39010 INTIMIDATOR SERIES MOTOR PLATE  
used in belt drive kits 16501, 16505, 16509, 16513



39009 INTIMIDATOR SERIES MOTOR PLATE  
used in belt drive kits 16500 16504, 16508, 16512

Intimidator  
Primary  
Belt Drives

Outboard  
Bearing  
Supports

Piranha  
Clutches

Intimidator  
Motor Plates  
& Accessories

Enclosed &  
Open Primary  
Belt Drives

Rear Belt  
Drives

Replacement  
Primary &  
Rear Belts

Replacement  
Pulleys

Replacement  
Components

Terms &  
Conditions  
Of Sale



# INTIMIDATOR SERIES PRIMARY BELT DRIVES - SOFTAIL

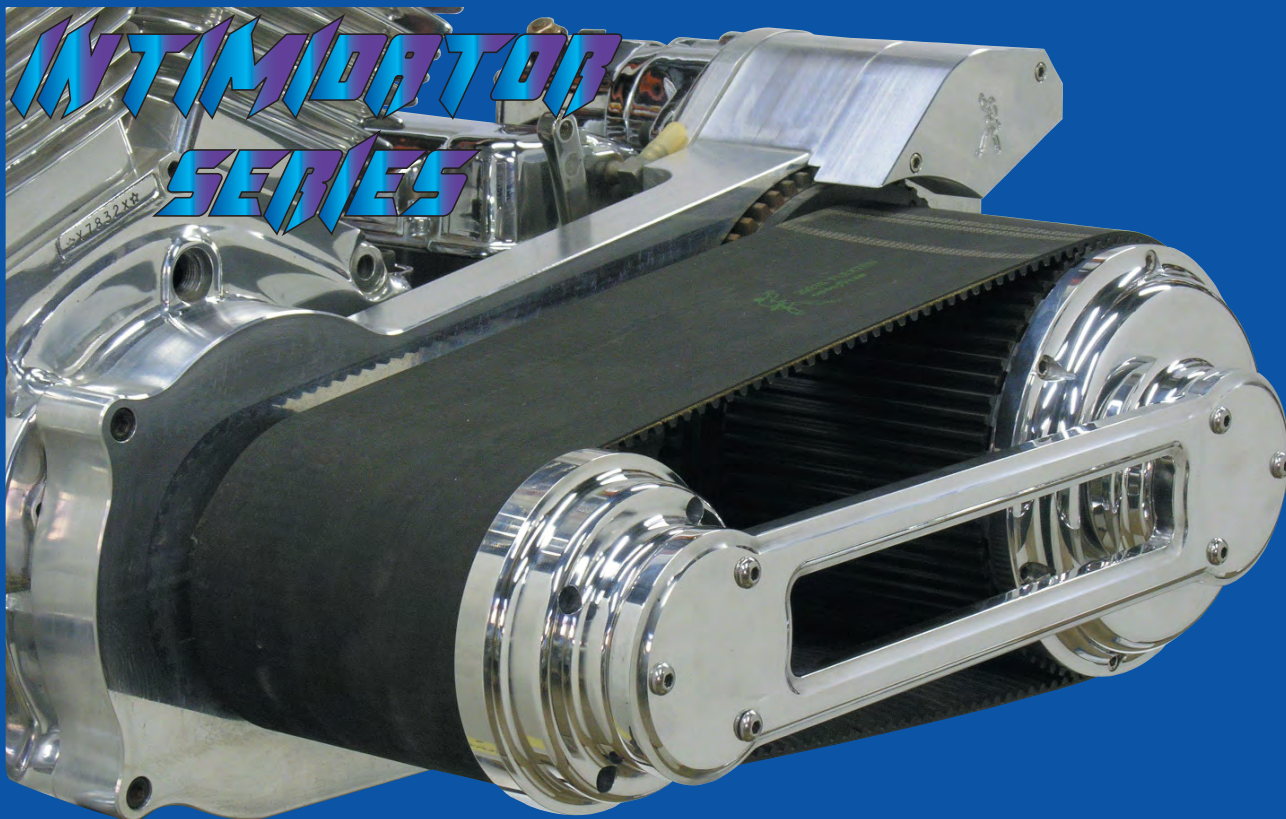

## SOFTAIL PRIMARY BELT DRIVES 3", 4", 5" WIDTHS LEFT-SIDE DRIVE & RIGHT SIDE DRIVE (RSD)

### THE ONE AND ONLY INTIMIDATOR

The belt drive that started it all, the awesome **KARATA INTIMIDATOR SERIES** is bigger, badder and better than ever.

### SIZE, SELECTION & FITMENT

Available in three sizes, massive 5", beefy 4" and traditional 3" these belt drives are designed to fit Evolution and Twin Cam Softail models from 1986 to present (1986-1989 models available in 3" only).

For custom motorcycles based on Softail-style frames or Rigid frames that use Softail-style components, the **INTIMIDATOR SERIES** primary belt drive is the only choice.

### OPTIONS

**KARATA'S** outboard bearing support system can be used on all **INTIMIDATOR SERIES** belt drives that accept 1990-up transmissions.

The outboard bearing support system is included with all 5" **INTIMIDATOR SERIES** belt drives and is an ideal option for 3" and 4" drives.

See **SECTION 2** for complete details on outboard bearing support systems.

### RIGHT SIDE DRIVE APPLICATIONS

**KARATA** is the first manufacturer in the industry to offer a dedicated family of Softail/Custom belt drives specifically for custom motorcycles using Right Side Drive (RSD) transmissions.

Look closely, and you'll see that all **INTIMIDATOR SERIES** primary belt drives that are for RSD applications feature a uniquely-machined motor plate that has no drive belt/chain cut outs. This feature allows for even greater strength and rigidity in addition to setting a new design standard for the industry.

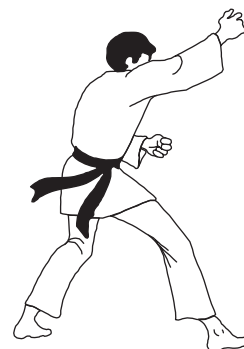

Intimidator  
Primary  
Belt Drives

Outboard  
Bearing  
Supports

Piranha  
Klutches

Intimidator  
Motor Plates  
& Accessories

Enclosed &  
Open Primary  
Belt Drives

Rear Belt  
Drives

Replacement  
Primary &  
Rear Belts

Replacement  
Pulleys

Replacement  
Components

Terms &  
Conditions  
Of Sale

# INTIMIDATOR SERIES PRIMARY BELT DRIVES - SOFTAIL

## LEFT-SIDE DRIVE KITS

1990-up Softail models

- 16401 3"
- 16404 4"
- 16407 5"

1986-89 Softail models

- 16435 3.00"

The **KARATA INTIMIDATOR SERIES** primary belt drive kits listed above can be ordered with offset motor plates.

**SEE SECTION 4 FOR DETAILS**



Offsets from .250" to 2.000" available! See Section 4 for details.

## RIGHT SIDE DRIVE (RSD) KITS

1990-up Softail models  
Right Side Drive

- 16402 3"
- 16405 4"
- 16408 5"

**KARATA INTIMIDATOR SERIES** Right Side Drive primary belt drive kits use dedicated RSD motor plates that feature no cut outs on the rear of the plate for the drive belt or chain. This unique feature is another **KARATA INNOVATION**.

Left Side Drive with cut outs

Right Side Drive no cut outs

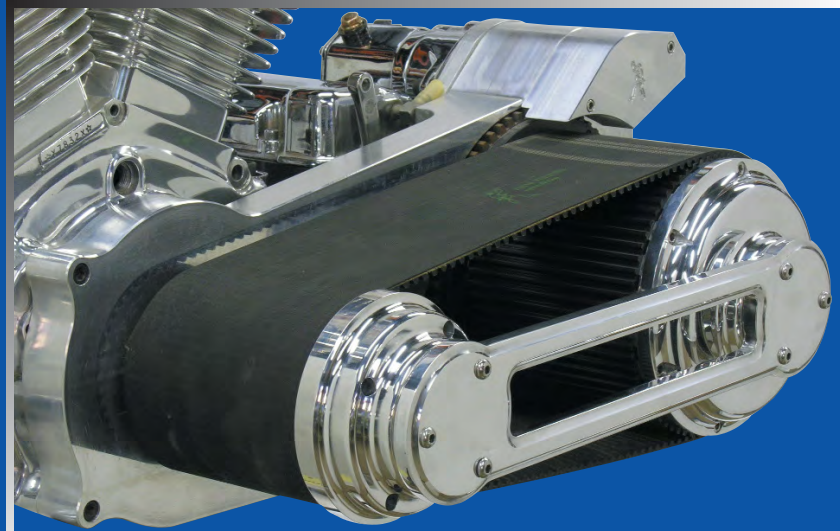

16407 INTIMIDATOR 5.0" primary belt drive with 16120 outer bearing support system

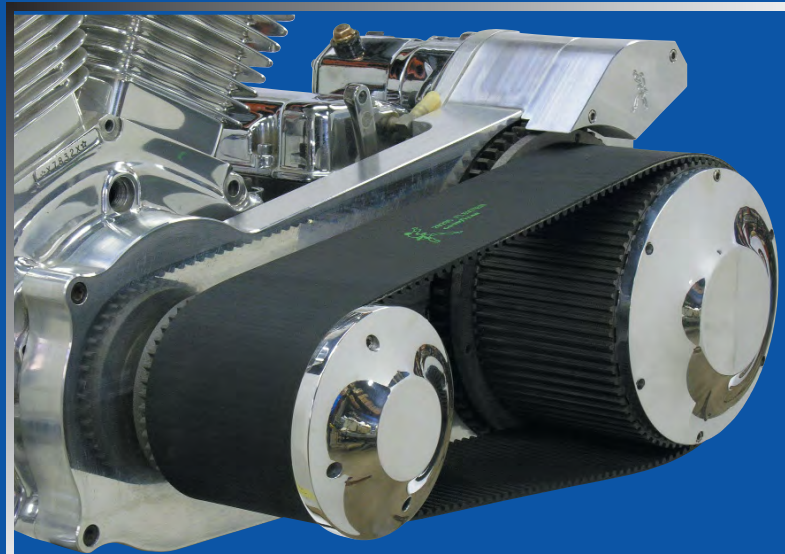

16404 INTIMIDATOR 4.0" primary belt drive with optional 40088 'Smoothie' front pulley cover & 40090 'Smoothie' rear pulley cover



16401 & 16435 INTIMIDATOR 3.0" primary belt drive with optional 40096 'Hubcap' front pulley cover & 40099 'Hubcap' rear pulley cover

Intimidator Primary Belt Drives

Outboard Bearing Supports

Piranha Klutches

Intimidator Motor Plates & Accessories

Enclosed & Open Primary Belt Drives

Rear Belt Drives

Replacement Primary & Rear Belts

Replacement Pulleys

Replacement Components

Terms & Conditions Of Sale



# INTIMIDATOR SERIES PRIMARY BELT DRIVES - SOFTAIL XCD

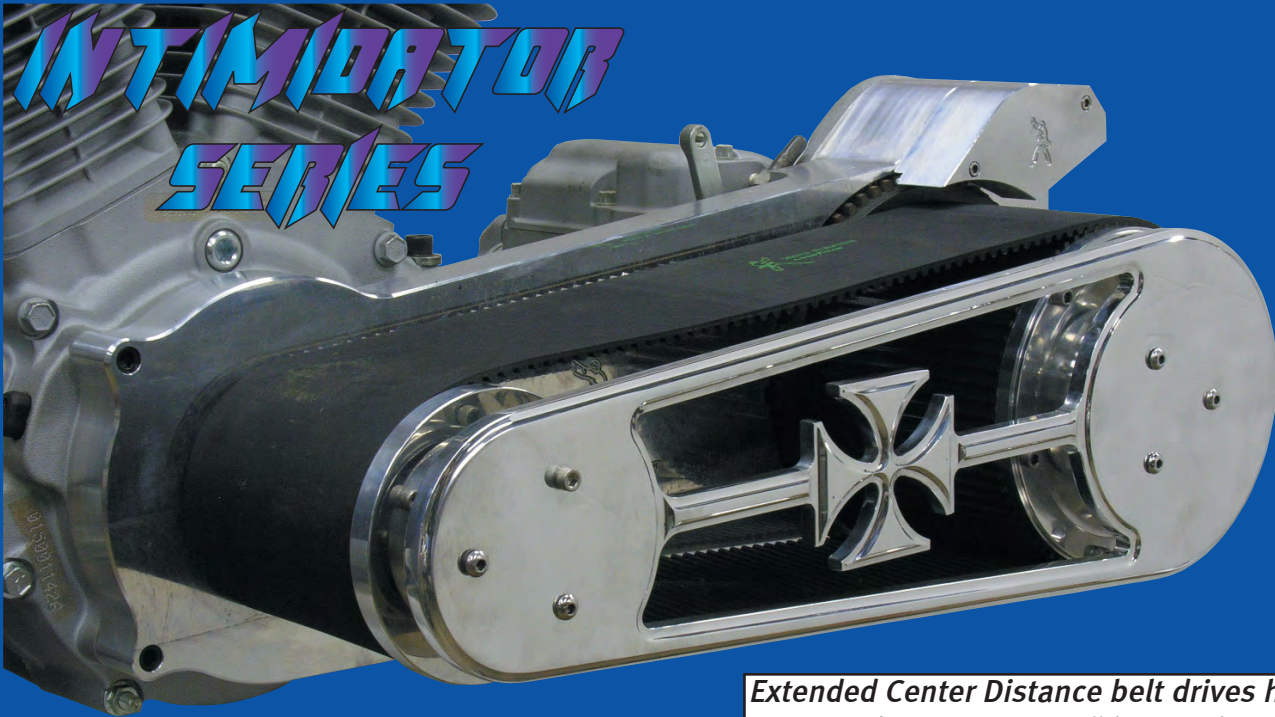

*Extended Center Distance belt drives have a center distance 3.2195" longer than stock!*

## EXTENDED CENTER DISTANCE (XCD) PRIMARY BELT DRIVES 3", 4", 5" WIDTHS LEFT-SIDE DRIVE & RIGHT SIDE DRIVE (RSD)

### THE ULTIMATE CUSTOM BELT DRIVE!

Karata's latest **INNOVATION** in primary belt drives is also the **ULTIMATE** belt drive for exotic custom motorcycles. The **INTIMIDATOR XCD** Extended Center Distance belt drive features a center distance that is 3.2195" longer than the standard **INTIMIDATOR SERIES** Softtail belt drives.

The **INTIMIDATOR XCD** is designed specifically for custom frames with extended powertrain mounts, and is available in standard Left-Side Drive and Right Side Drive (RSD). The **INTIMIDATOR XCD** will **NOT** work on stock motorcycles or custom motorcycles with stock-style frames.

### SIZE, SELECTION & FITMENT

Available in three sizes, massive 5", beefy 4" and traditional 3" these belt drives are designed to fit Evolution and Twin Cam Softtail models.

For custom motorcycles based on Softtail-style frames or Rigid frames that use Softtail-style components, the **INTIMIDATOR SERIES** primary belt drive is the only choice.

### XCD OPTIONS

**KARATA'S** outboard bearing support system can be used on all **INTIMIDATOR SERIES** belt drives that accept 1990-up transmissions.

The outboard bearing support system is included with all 5" **INTIMIDATOR SERIES** belt drives and is an ideal option for 3" and 4" drives.

See **SECTION 2** for complete details on outboard bearing support systems.

### RIGHT SIDE DRIVE APPLICATIONS

**KARATA** is the first manufacturer in the industry to offer a dedicated family of Softtail/Custom belt drives specifically for custom motorcycles using Right Side Drive (RSD) transmissions.

Look close, and you'll see that all **INTIMIDATOR SERIES** primary belt drives that are for RSD applications feature a uniquely-machined motor plate that has no drive belt/chain cut outs. This feature allows for even greater strength and rigidity in addition to setting a new design standard for the industry.

Intimidator  
Primary  
Belt Drives

Outboard  
Bearing  
Supports

Piranha  
Klutches

Intimidator  
Motor Plates  
& Accessories

Enclosed &  
Open Primary  
Belt Drives

Rear Belt  
Drives

Replacement  
Primary &  
Rear Belts

Replacement  
Pulleys

Replacement  
Components

Terms &  
Conditions  
Of Sale

# INTIMIDATOR SERIES PRIMARY BELT DRIVES - SOFTAIL XCD

## LEFT-SIDE DRIVE KITS

1990-up Softail models  
Extended Center Distance

16410	3"
16413	4"
16416	5"

The **KARATA INTIMIDATOR SERIES Extended Center Distance (XCD)** primary belt drive kits listed above can be ordered with .500" offset motor plates.

**SEE SECTION 4 FOR DETAILS**

# XCD

EXTENDED CENTER DISTANCE

## RIGHT SIDE DRIVE (RSD) KITS

1990-up Softail models,  
Extended Center Distance,  
Right Side Drive

16411	3"
16414	4"
16417	5"

**KARATA INTIMIDATOR SERIES** Right Side Drive primary belt drive kits use dedicated RSD motor plates that feature no cut outs on the rear of the plate for the drive belt or chain. This unique feature is another **KARATA INNOVATION**.

Left Side Drive  
with cut outs



Right Side Drive  
no cut outs

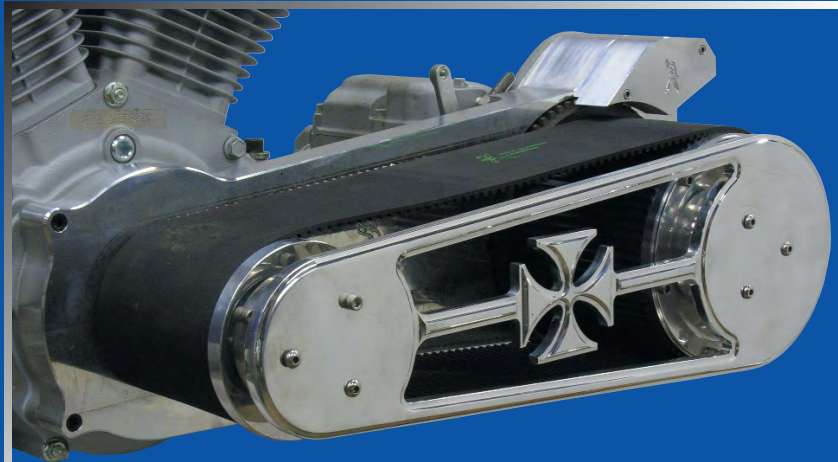

**16416 INTIMIDATOR 5.0"** Extended Center Distance (XCD) primary belt drive with **16165XCD** outer bearing support system



**16413 INTIMIDATOR 4.0"** Extended Center Distance (XCD) primary belt drive with **16165XCD** outer bearing support system



**16410 INTIMIDATOR 3.0"** Extended Center Distance (XCD) primary belt drive with **40096** 'Hubcap' front pulley cove and **40099** 'Hubcap' rear pulley cover

Intimidator  
Primary  
Belt Drives

Outboard  
Bearing  
Supports

Piranha  
Clutches

Intimidator  
Motor Plates  
& Accessories

Enclosed &  
Open Primary  
Belt Drives

Rear Belt  
Drives

Replacement  
Primary &  
Rear Belts

Replacement  
Pulleys

Replacement  
Components

Terms &  
Conditions  
Of Sale



# INTIMIDATOR SERIES PRIMARY BELT DRIVES - SPECIAL APPLICATIONS

## INTIMIDATOR SERIES

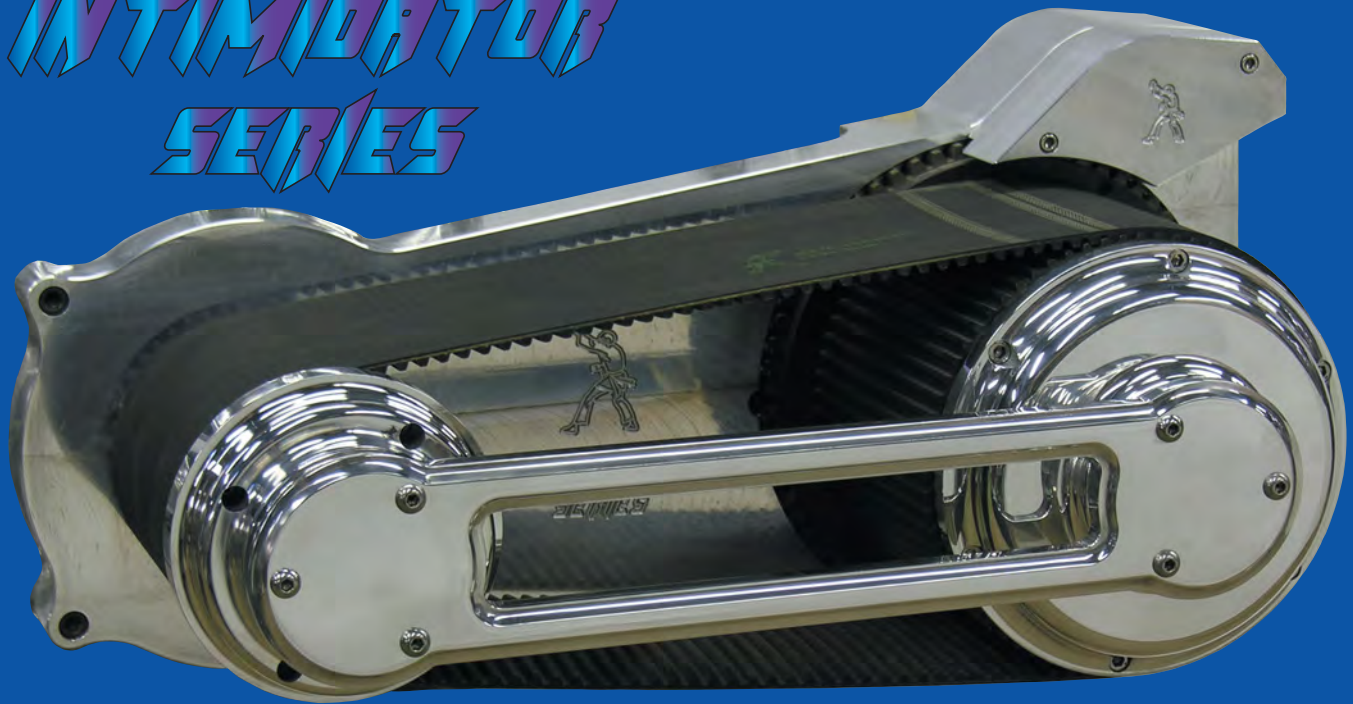

## TWIN CAM SOFTAIL & EVOLUTION DYNA PRIMARY BELT DRIVES 3", 4", 5" WIDTHS LEFT-SIDE DRIVE WIDE TIRE SOLUTIONS

### TWIN CAM SOFTAIL WIDE TIRE SOLUTIONS FOR MODELS USING PAUL YAFFE ORIGINALS & PERFORMANCE MACHINE OFFSET KITS

**KARATA'S** continuing commitment to innovation has resulted in the design and manufacture of **INTIMIDATOR SERIES** primary belt drives for use with many of today's most popular wide tire conversion kits. Dedicated **INTIMIDATOR SERIES** motor plates are available for 2000-up Twin Cam Softail models equipped with wide tire kits from Paul Yaffe Originals and Performance Machine, for 2002-up Dyna models and Arlen Ness Y2K motorcycles using a 1993-2001 Dyna-style transmission.

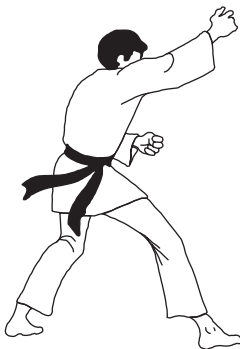

### SIZE, SELECTION & FITMENT

With Performance Machine's wide tire kit, the primary is offset 1" outboard. **KARATA** manufactures a special **INTIMIDATOR SERIES** motor plate that has a 1" offset at the engine and transmission. Paul Yaffe Originals' wide tire kit moves the primary outboard 45mm (1.770"). **KARATA'S INTIMIDATOR SERIES** motor plate for this application has a massive 45mm offset at the engine and transmission.

Likewise, the **INTIMIDATOR SERIES** motor plate for 2002-up Dyna models and the Ness Y2K Dyna chassis also features a 1-inch engine and transmission offset.

### OPTIONS

**KARATA'S** outboard bearing support system can be used on all **INTIMIDATOR SERIES** belt drives that accept 1990-up transmissions.

The outboard bearing support system is included with all 5" **INTIMIDATOR SERIES** belt drives and is an ideal option for 3" and 4" drives.

See **SECTION 2** for complete details on outboard bearing support systems.

Intimidator  
Primary  
Belt Drives

Outboard  
Bearing  
Supports

Piranha  
Klutches

Intimidator  
Motor Plates  
& Accessories

Enclosed &  
Open Primary  
Belt Drives

Rear Belt  
Drives

Replacement  
Primary &  
Rear Belts

Replacement  
Pulleys

Replacement  
Components

Terms &  
Conditions  
Of Sale

# INTIMIDATOR SERIES PRIMARY BELT DRIVES - SPECIAL APPLICATIONS

## LEFT-SIDE DRIVE KITS

2000-up Softail models  
with Performance Machine 1 1/2" engine/transmission offset

16425 3"  
16426 4"  
16427 5"

2000-up Softail models  
with Paul Yaffe Originals  
45mm/45mm  
engine/transmission offset

16420 3"  
16421 4"  
16422 5"

Arlen Ness Y2K models with  
1 1/2" engine/transmission offset  
1993-2001 Dyna transmission

16437 3"  
16438 4"  
16439 5"

Dyna models with  
1 1/2" engine/transmission offset  
2002-up Dyna transmission

16446 3"  
16447 4"  
16448 5"

# KARATA

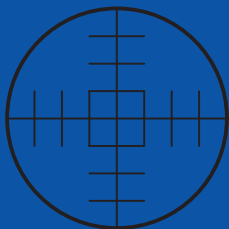

## SPECIAL OPS

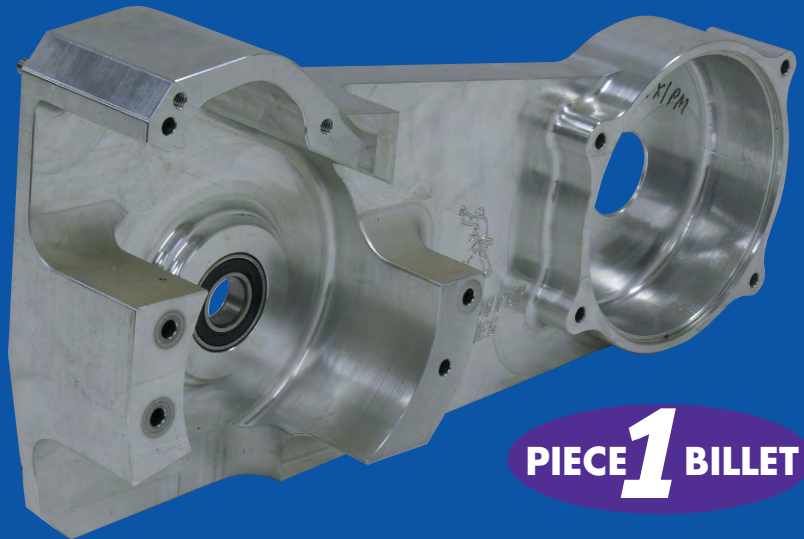

**PIECE 1 BILLET**

**39006 INTIMIDATOR SERIES MOTOR PLATE**  
used in belt drive kits 16425, 16426, 16427 for PM wide tire kits



**PIECE 1 BILLET**

**39007 INTIMIDATOR SERIES MOTOR PLATE**  
used in belt drive kits 16420, 16421, 16422 for PYO wide tire kits



**PIECE 1 BILLET**

**39014/39015 INTIMIDATOR SERIES MOTOR PLATE**  
used in belt drive kits for 2002-up Dyna and Ness Y2K models

Intimidator  
Primary  
Belt Drives

Outboard  
Bearing  
Supports

Piranha  
Clutches

Intimidator  
Motor Plates  
& Accessories

Enclosed &  
Open Primary  
Belt Drives

Rear Belt  
Drives

Replacement  
Primary &  
Rear Belts

Replacement  
Pulleys

Replacement  
Components

Terms &  
Conditions  
Of Sale



# INTIMIDATOR SERIES PRIMARY BELT DRIVES - DYNA

Intimidator  
Primary  
Belt Drives

Outboard  
Bearing  
Supports

Piranha  
Klutches

Intimidator  
Motor Plates  
& Accessories

Enclosed &  
Open Primary  
Belt Drives

Rear Belt  
Drives

Replacement  
Primary &  
Rear Belts

Replacement  
Pulleys

Replacement  
Components

Terms &  
Conditions  
Of Sale

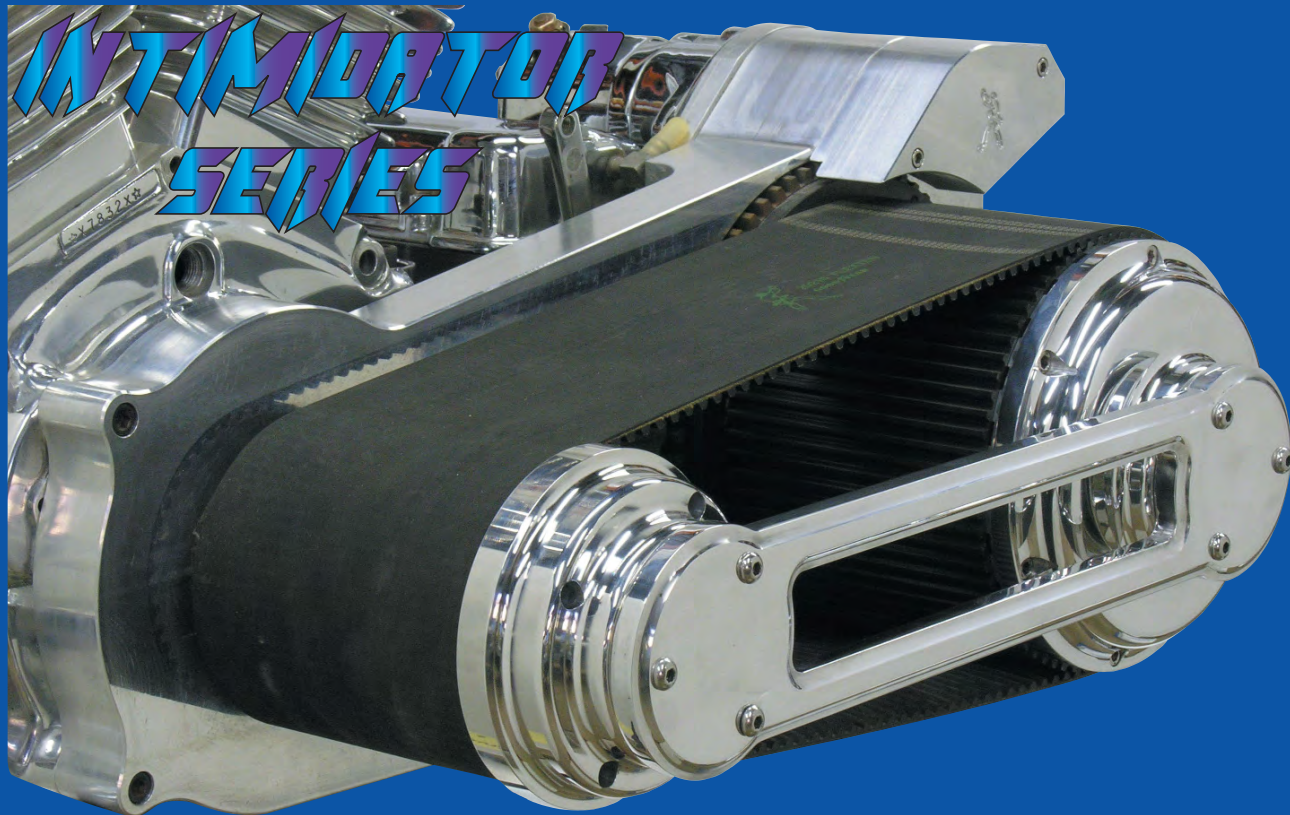

## DYNA PRIMARY BELT DRIVES 3", 4", 5" WIDTHS LEFT-SIDE DRIVE

### SIZE, SELECTION & FITMENT

Available in three sizes, massive 5", beefy 4" and traditional 3" **INTIMIDATOR SERIES** belt drives are designed to fit Evolution and Twin Cam Dyna models from 1993 to present.

For custom motorcycles based on Dyna-style frames, the **INTIMIDATOR SERIES** primary belt drive is the only choice.

### OPTIONS

**KARATA'S** outboard bearing support system can be used on all **INTIMIDATOR SERIES** belt drives that accept 1990-up transmissions.

The outboard bearing support system is included with all 5" **INTIMIDATOR SERIES** belt drives and is an ideal option for 3" and 4" drives.

See **SECTION 2** for complete details on outboard bearing support systems.

This added support boss is a standard feature on all **INTIMIDATOR SERIES** Dyna motor plates. It adds additional support for the transmission and is a **KARATA** exclusive.

### WIDE TIRE APPLICATIONS

**KARATA INTIMIDATOR SERIES** Dyna primary belt drive kits are available with non-offset motor plates for 1993-2001 models and for 2002-up models and for custom motorcycles that use Dyna-style frames.

For 1993-2001 and 2002-up models and custom motorcycles that use wide-tire Dyna-style frames, **KARATA** offers a billet motor plate with a 1.00" offset at the engine AND transmission. And for the ultimate in custom, Right Side Drive Dyna kits for 1993-2001 models are now available!

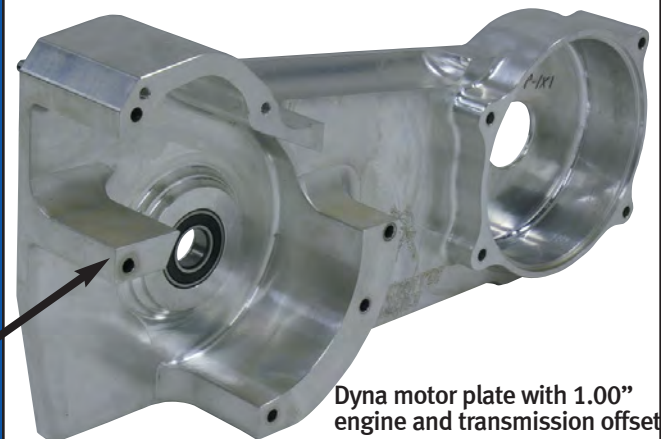

Dyna motor plate with 1.00" engine and transmission offset



# INTIMIDATOR SERIES PRIMARY BELT DRIVES - DYNA

## LEFT-SIDE DRIVE KITS

1993-2001 Dyna models

16440 3"  
16441 4"  
16442 5"

2002-up Dyna models

16443 3"  
16444 4"  
16445 5"

The **KARATA INTIMIDATOR SERIES** Dyna belt drives listed above use non-offset motor plates only.

## LEFT-SIDE DRIVE KITS WITH 1.00" OFFSET

1993-2001 Dyna models

16437 3"  
16438 4"  
16439 5"

2002-up Dyna models  
1.00" Engine & Transmission offset

16446 3"  
16447 4"  
16448 5"

The **KARATA INTIMIDATOR SERIES** Dyna belt drives listed above use offset motor plates that feature a 1.00" offset at the engine and transmission.

**SEE SECTION 4 FOR DETAILS**

## RIGHT SIDE DRIVE (RSD) KITS

1993-2001 Dyna models

Right Side Drive

16440A 3"  
16441A 4"  
16442A 5"

**KARATA INTIMIDATOR SERIES** Right Side Drive primary belt drive kits use dedicated RSD motor plates that feature no cut outs on the rear of the plate for the drive belt or chain. This unique feature is another **KARATA INNOVATION**.

Left Side Drive  
with cut outs

Right Side Drive  
no cut outs

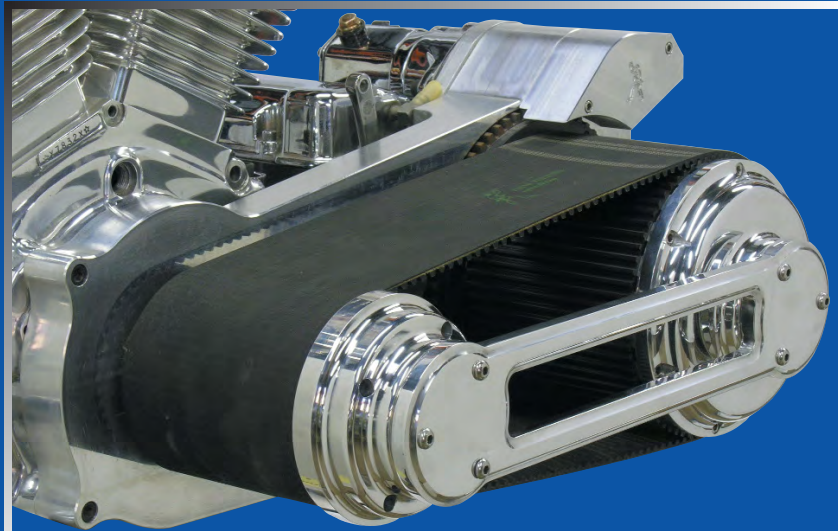

16442 & 16445 INTIMIDATOR 5.0" primary belt drive with 16120 outer bearing support system

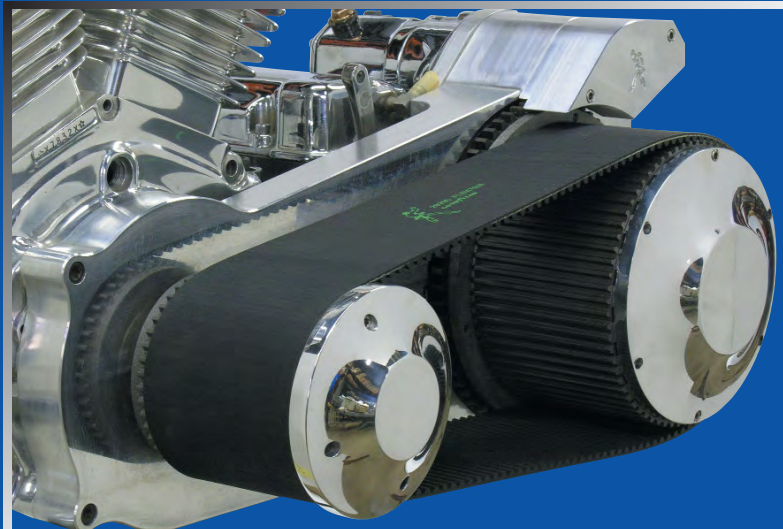

16441 & 16444 INTIMIDATOR 4.0" primary belt drive with optional 40088 'Smoothie' front pulley cover and 40090 'Smoothie' rear pulley cover



16440 & 16443 INTIMIDATOR 3.0" primary belt drive with optional 40096 'Hubcap' front pulley cover and 40099 'Hubcap' rear pulley cover

Intimidator  
Primary  
Belt Drives

Outboard  
Bearing  
Supports

Piranha  
Clutches

Intimidator  
Motor Plates  
& Accessories

Enclosed &  
Open Primary  
Belt Drives

Rear Belt  
Drives

Replacement  
Primary &  
Rear Belts

Replacement  
Pulleys

Replacement  
Components

Terms &  
Conditions  
Of Sale



# INTIMIDATOR SERIES PRIMARY BELT DRIVES - FXR

Intimidator  
Primary  
Belt Drives

Outboard  
Bearing  
Supports

Piranha  
Klutches

Intimidator  
Motor Plates  
& Accessories

Enclosed &  
Open Primary  
Belt Drives

Rear Belt  
Drives

Replacement  
Primary &  
Rear Belts

Replacement  
Pulleys

Replacement  
Components

Terms &  
Conditions  
Of Sale

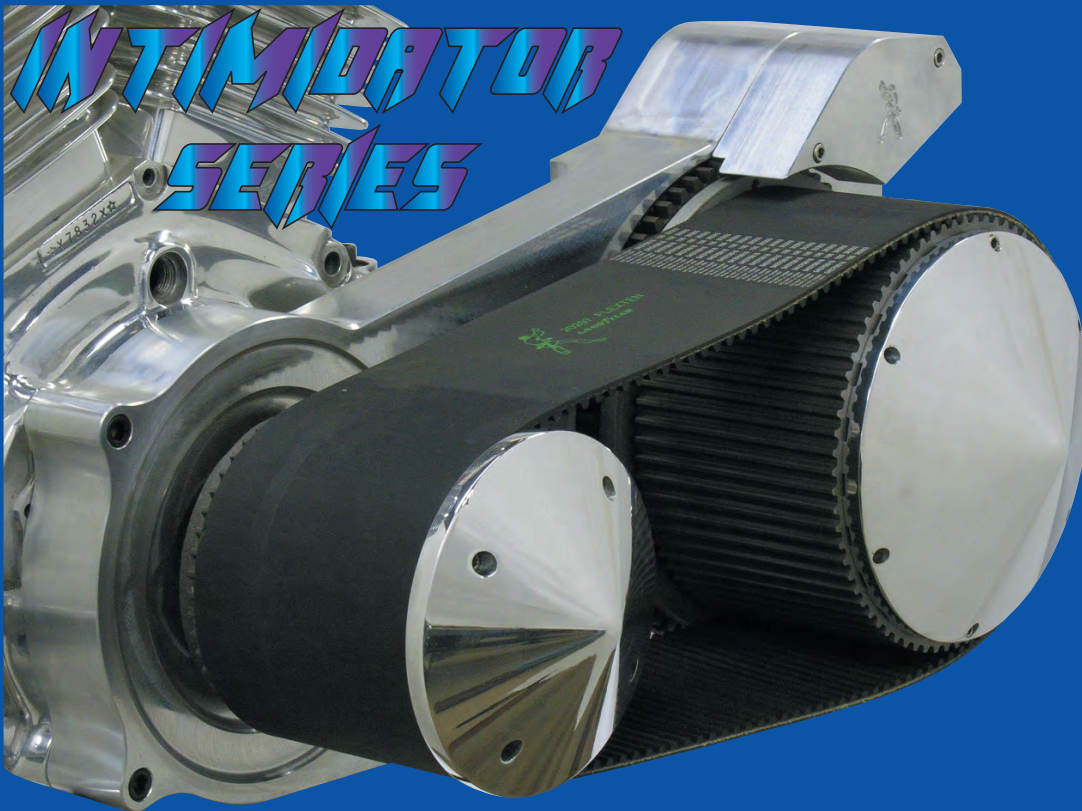

## FXR PRIMARY BELT DRIVES 3", 4" WIDTHS LEFT-SIDE DRIVE

### SIZE, SELECTION & FITMENT

Not just for Softail and Dyna models, **INTIMIDATOR SERIES** primary belt drives are available for FXR models in two sizes: beefy 4" and traditional 3". These belt drives are designed to fit Evolution FXR models from 1990-up.

For custom motorcycles based on FXR-style frames or special frames that use FXR-style components, the **INTIMIDATOR SERIES** primary belt drive is the only choice.

### OPTIONS

**KARATA'S** outboard bearing support system can be used on all **INTIMIDATOR SERIES** belt drives that accept 1990-up transmissions.

The outboard bearing support system is an ideal option for **INTIMIDATOR SERIES** 3" and 4" belt drives.

See **SECTION 2** for complete details on outboard bearing support systems.

### WIDE TIRE APPLICATIONS

**KARATA INTIMIDATOR SERIES** FXR primary belt drive kits are available with non-offset motor plates for 1990-up models and custom motorcycles that use FXR-style frames.

For wide-tire applications, **KARATA** offers a one-piece billet motor plate with a 1.00" offset. Modification of the transmission case and swingarm may be required, depending on the frame manufacturer.

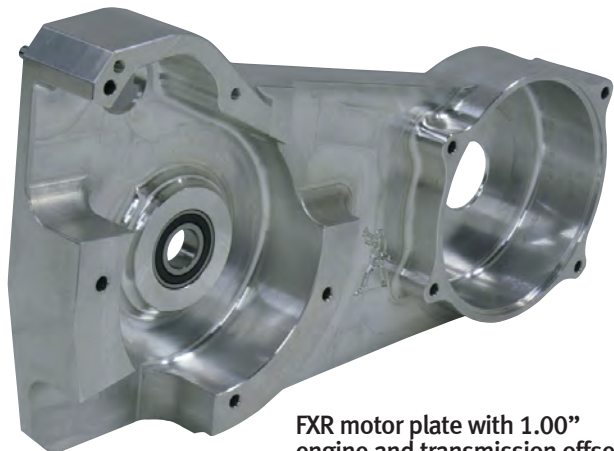

FXR motor plate with 1.00" engine and transmission offset

# INTIMIDATOR SERIES PRIMARY BELT DRIVES - FXR

## LEFT-SIDE DRIVE KITS

1990-up FXR models  
 16450 3"  
 16451 4"

The **KARATA INTIMIDATOR SERIES** FXR belt drives listed above use non-offset motor plates only.



**16451 INTIMIDATOR 4.0"** primary belt drive with **40097 'Hubcap'** front pulley cover and **40099 'Hubcap'** rear pulley cover



**16450 INTIMIDATOR 3.0"** primary belt drive with optional **40097 'Hubcap'** front pulley cover and **40099 'Hubcap'** rear pulley cover

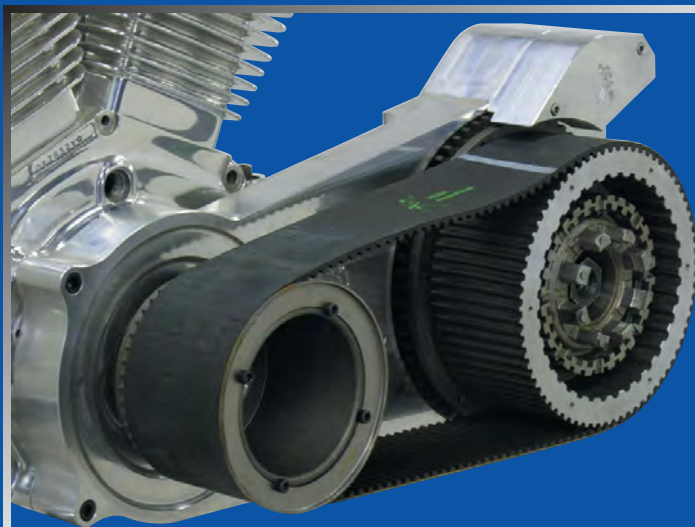

**16450 INTIMIDATOR 3.0"** primary belt drive without pulley covers or outboard bearing support system

## LEFT-SIDE DRIVE KITS WITH 1.00" OFFSET

1990-up FXR models  
 1.00" Engine offset  
 16453 3"  
 16454 4"

The **KARATA INTIMIDATOR SERIES** FXR belt drives listed above use 1.000" engine offset motor plates.

**SEE SECTION 4 FOR DETAILS**

**FXR**  
**WIDE**  
 TIRE SOLUTIONS

Intimidator  
Primary  
Belt Drives

Outboard  
Bearing  
Supports

Piranha  
Clutches

Intimidator  
Motor Plates  
& Accessories

Enclosed &  
Open Primary  
Belt Drives

Rear Belt  
Drives

Replacement  
Primary &  
Rear Belts

Replacement  
Pulleys

Replacement  
Components

Terms &  
Conditions  
Of Sale



# INTIMIDATOR SERIES PRIMARY BELT DRIVES - ROAD KING/FLT

# INTIMIDATOR SERIES



## ROAD KING/FLT PRIMARY BELT DRIVES 3", 4" WIDTHS LEFT-SIDE DRIVE

### SIZE, SELECTION & FITMENT

Not just for Softail and Dyna models, **INTIMIDATOR SERIES** primary belt drives are available for Road King/FLT models in two sizes, beefy 4" and traditional 3". These belt drives are designed to fit Evolution and Twin Cam Road King/FLT models from 1994-present.

### OPTIONS

**KARATA'S** outboard bearing support system can be used on all **INTIMIDATOR SERIES** belt drives that accept 1990-up transmissions.

The outboard bearing support system is an ideal option for **INTIMIDATOR SERIES** 3" and 4" belt drives.

See **SECTION 2** for complete details on outboard bearing support systems.

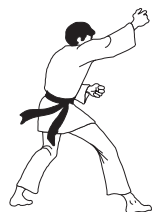

### DEDICATED ROAD KING/FLT DESIGN

**KARATA INTIMIDATOR SERIES** Road King/FLT primary belt drive kits are available with motor plates specifically designed for Road King/FLT models.

To allow the continued use of floorboards and OEM foot controls, **KARATA** has machined a bushing boss into the **INTIMIDATOR SERIES** motor plate to allow use of the OEM foot shifter. This innovation is another example of **KARATA'S** commitment to designing and manufacturing the widest selection of primary belt drives available.



Intimidator  
Primary  
Belt Drives

Outboard  
Bearing  
Supports

Piranha  
Klutches

Intimidator  
Motor Plates  
& Accessories

Enclosed &  
Open Primary  
Belt Drives

Rear Belt  
Drives

Replacement  
Primary &  
Rear Belts

Replacement  
Pulleys

Replacement  
Components

Terms &  
Conditions  
Of Sale

# INTIMIDATOR SERIES PRIMARY BELT DRIVES - ROAD KING/FLT

## LEFT-SIDE DRIVE KITS

2002-up Road King/FLT models

16459 3"

16460 4"

1994-2001 Road King/FLT models

16457 3"

16458 4"

The **KARATA INTIMIDATOR SERIES** Road King/FLT belt drives listed above use non-offset motor plates only.

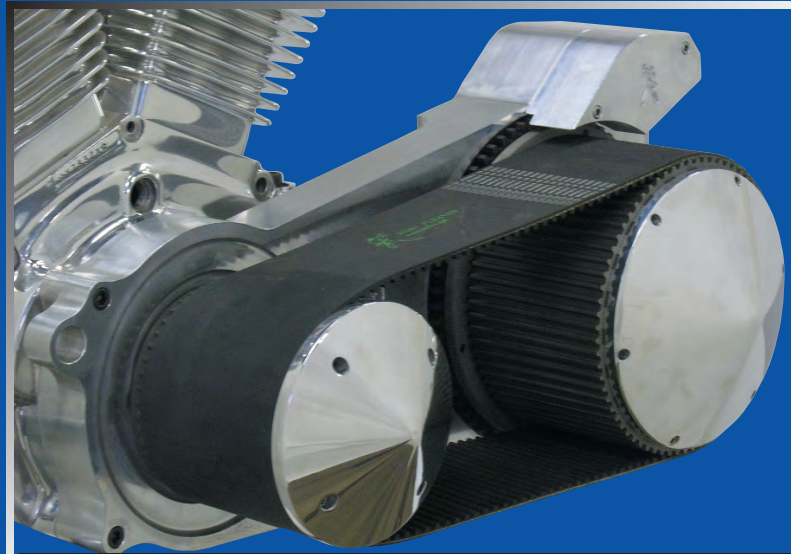

**16460 INTIMIDATOR 4.0"** primary belt drive with **40097 'Hubcap'** front pulley cover and **40099 'Hubcap'** rear pulley cover

Intimidator  
Primary  
Belt Drives

Outboard  
Bearing  
Supports

Piranha  
Clutches

Intimidator  
Motor Plates  
& Accessories

DEDICATED  
**FLT / ROAD KING**  
DESIGN  
KARATA INNOVATION

**KARATA'S INTIMIDATOR SERIES** motor plate for FLT and Road King models was designed SPECIFICALLY for these bikes. At KARATA, we pride ourselves on having one of the largest model-specific product lines in the business!

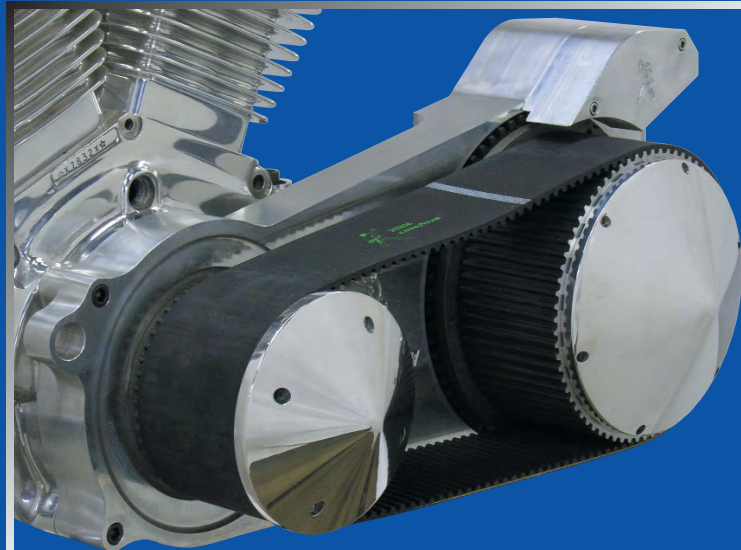

**16459 INTIMIDATOR 3.0"** primary belt drive with optional **40097 'Hubcap'** front pulley cover and **40099 'Hubcap'** rear pulley cover

Enclosed &  
Open Primary  
Belt Drives

Rear Belt  
Drives

Replacement  
Primary &  
Rear Belts

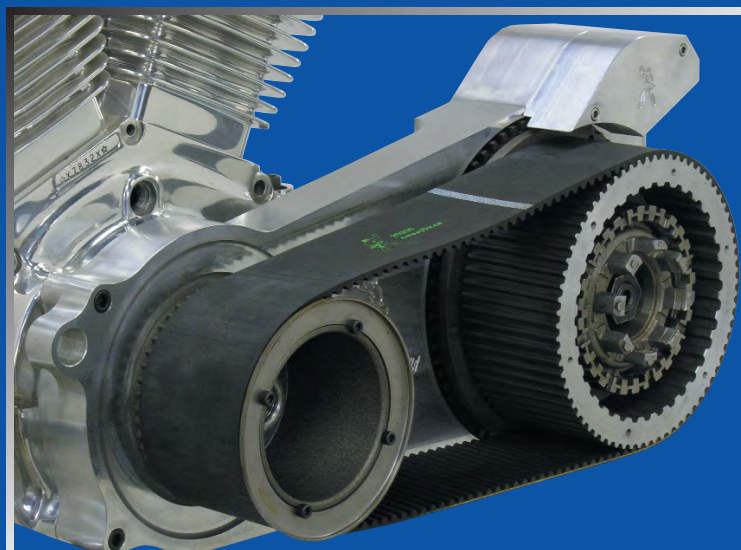

**16459 INTIMIDATOR 3.0"** primary belt drive without pulley covers or outboard bearing support system

Replacement  
Pulleys

Replacement  
Components

Terms &  
Conditions  
Of Sale



# INTIMIDATOR SERIES PRIMARY BELT DRIVES - FX/FL 5-SPEED CONVERSION

## INTIMIDATOR SERIES

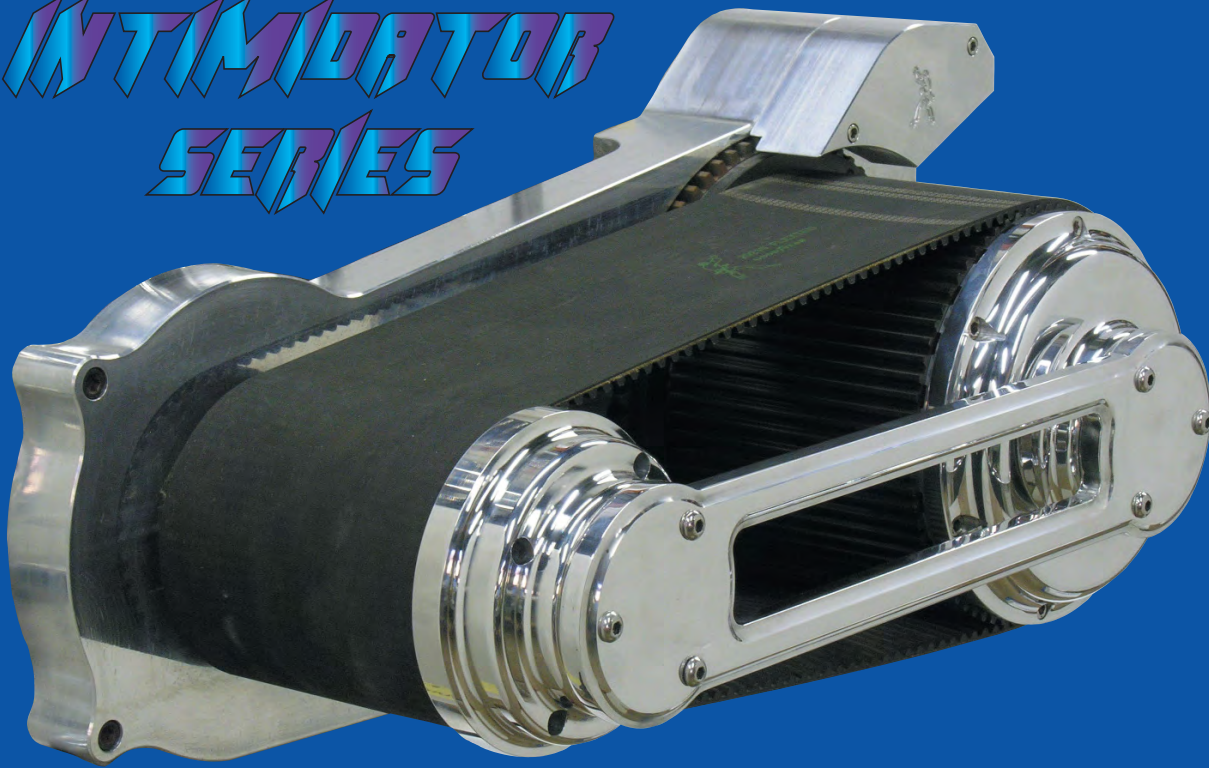

## SHOVELHEAD/EVOLUTION 4-SPEED SWING ARM FRAME PRIMARY BELT DRIVES 3", 4", 5" WIDTHS LEFT-SIDE DRIVE - SOFTAIL 5-SPEED CONVERSION

### CONVERT ANY 1970-1984 FX/FL 4-SPEED MODEL TO A SOFTAIL 5-SPEED

**KARATA'S INTIMIDATOR SERIES** primary belt drives are designed to work on Big Twin models from 1936 to present. Not just for Softails, **INTIMIDATOR SERIES** belt drives for Shovelhead (and early Evolution FX) models offer a wide selection for upgrading classic 4-speed FX/FL models.

Available in three sizes, massive 5", beefy 4" and traditional 3", this innovative **INTIMIDATOR SERIES** primary belt drive converts any 1970-1984 FX/FL 4-speed swingarm model to accept a 1990-1999 Softail-style 5-speed transmission. This combination installs in the 4-speed swingarm frame with only a slight modification to the transmission case and provides a perfect upgrade to the traditional 4-speed swingarm frame.

For custom motorcycles that use aftermarket 4-speed-style frames or Rigid frames that use ratchet-top 4-speed transmissions, this **INTIMIDATOR SERIES** primary belt drive offers new options for custom motorcycle design.

### OPTIONS

**KARATA'S** outboard bearing support system can be used on all **INTIMIDATOR SERIES** belt drives that accept 1990-up transmissions.

The outboard bearing support system is included with all 5" **INTIMIDATOR SERIES** belt drives and is an ideal option for 3" and 4" drives.

See **SECTION 2** for complete details on outboard bearing support systems.

### CUSTOM OPTIONS FOR CUSTOM BIKES

**INTIMIDATOR SERIES** primary belt drives #16430 - 16432 (listed on page 1-19) are designed for custom motorcycles that use OEM or aftermarket 4-speed-style frames or Rigid frames that use ratchet-top 4-speed transmissions. For 1990-1999 Softail transmission conversions, many aftermarket Softail and rigid frames can be used.

Regardless of which transmission option you choose, the **INTIMIDATOR SERIES** primary belt drives offer new options for custom motorcycle design.

Intimidator  
Primary  
Belt Drives

Outboard  
Bearing  
Supports

Piranha  
Klutches

Intimidator  
Motor Plates  
& Accessories

Enclosed &  
Open Primary  
Belt Drives

Rear Belt  
Drives

Replacement  
Primary &  
Rear Belts

Replacement  
Pulleys

Replacement  
Components

Terms &  
Conditions  
Of Sale

# INTIMIDATOR SERIES PRIMARY BELT DRIVES - FX/FL 5-SPEED CONVERSION

## LEFT-SIDE DRIVE KITS

1970-1984 4-speed FX/FL  
swingarm models - Conversion to  
1990-1999 Softail transmission

16430	3"
16431	4"
16432	5"

The **KARATA INTIMIDATOR SERIES** primary belt drive kits listed above can be ordered with offset motor plates.

**SEE SECTION 4 FOR DETAILS**



Offsets from .250" to 2.000" available! See Section 4 for details.

This special **INTIMIDATOR SERIES** motor plate allows a 1990-1999 Softail 5-speed transmission to be installed in a 4-speed FX-style frame. Only 3 of the 4 mounting bolts are used to secure the motor plate to the transmission, and a special cut out on the back of the plate provides swingarm clearance.

Swingarm pivot tube cut-out on motor plate

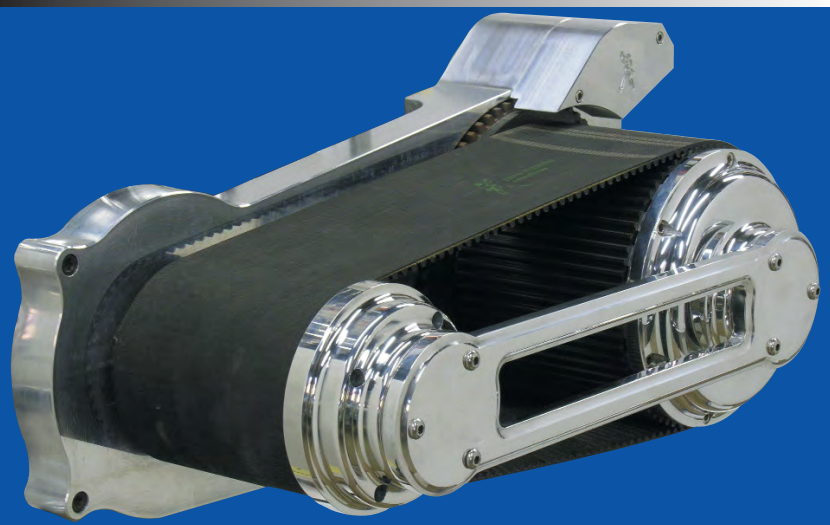
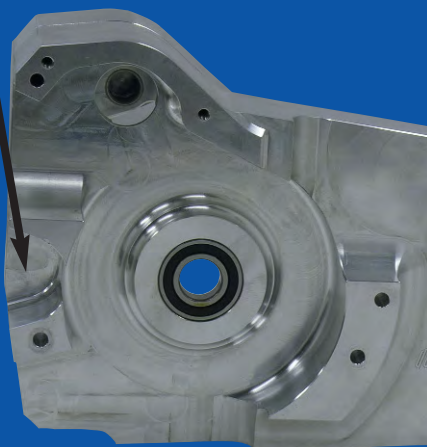

16432 INTIMIDATOR 5.0" primary belt drive with 16120 outer bearing support system

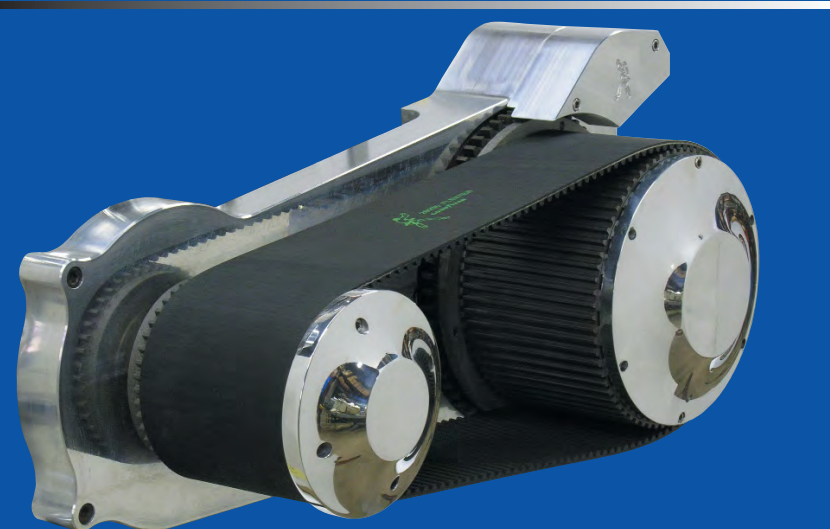

16431 INTIMIDATOR 4.0" primary belt drive with optional 40088 'Smoothie' front pulley cover and 40090 'Smoothie' rear pulley cover

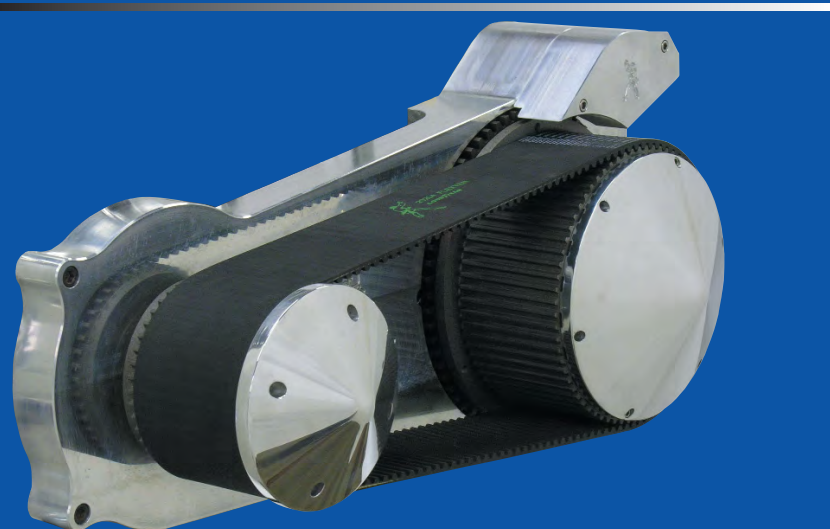

16430 INTIMIDATOR 3.0" primary belt drive with optional 40096 'Hubcap' front pulley cover and 40099 'Hubcap' rear pulley cover

Intimidator Primary Belt Drives

Outboard Bearing Supports

Piranha Clutches

Intimidator Motor Plates & Accessories

Enclosed & Open Primary Belt Drives

Rear Belt Drives

Replacement Primary & Rear Belts

Replacement Pulleys

Replacement Components

Terms & Conditions Of Sale



# INTIMIDATOR SERIES PRIMARY BELT DRIVES - FX/FL 4-SPEED/5-IN-4

# INTIMIDATOR SERIES



## SHOVELHEAD/EARLY EVOLUTION FX/FL PRIMARY BELT DRIVES 3", 4" WIDTHS LEFT-SIDE DRIVE - 4-SPEED & 5-IN-4 TRANSMISSIONS

### 1970-1984 FX/FL 4-SPEED MODELS WITH 1973-1978 4-SPEEDS OR AFTERMARKET 5-IN-4 TRANSMISSIONS

Any 1970-1984 FX/FL 4-speed swingarm model can be fitted with a **KARATA INTIMIDATOR SERIES** primary belt drive. These belt drives are available for motorcycles running either 1973-1978 Ratchet Top 4-speeds or 5-in-4 transmission conversions and are available in two sizes, beefy 4" and traditional 3".

### CUSTOM APPLICATIONS

For custom motorcycles that use aftermarket 4-speed-style frames or Rigid frames that use ratchet-top 4-speed or aftermarket 5-in-4 transmissions, this **INTIMIDATOR SERIES** primary belt drive is a perfect choice.



Intimidator  
Primary  
Belt Drives

Outboard  
Bearing  
Supports

Piranha  
Klutches

Intimidator  
Motor Plates  
& Accessories

Enclosed &  
Open Primary  
Belt Drives

Rear Belt  
Drives

Replacement  
Primary &  
Rear Belts

Replacement  
Pulleys

Replacement  
Components

Terms &  
Conditions  
Of Sale

# INTIMIDATOR SERIES PRIMARY BELT DRIVES - FX/FL 4-SPEED/5-IN-4

## LEFT-SIDE DRIVE KITS

1970-1984 4-speed FX/FL models  
with 1973-1978 Ratchet Top 4-  
speed transmission

16464 3"

16465 4"

1970-1984 4-speed FX/FL models  
with aftermarket 5-in-4 transmis-  
sion

16466 3"

16467 4"

The **KARATA INTIMIDATOR SERIES** primary belt drive kits listed above can be ordered with offset motor plates.

**SEE SECTION 4 FOR DETAILS**



**KARATA'S INTIMIDATOR SERIES** belt drives give you options. Whether you run a ratchet-top 4-speed or a 5-in-4 transmission, **KARATA** has you covered!



**16465 INTIMIDATOR 4.0"** primary belt drive without front pulley cover - See **Section 4** for front pulley covers

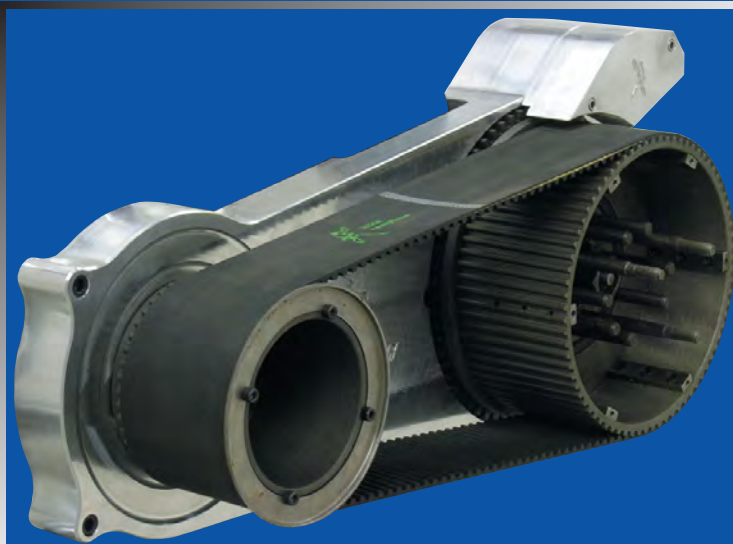

**16464 INTIMIDATOR 3.0"** primary belt drive without front or rear pulley cover - See **Section 4** for front pulley covers

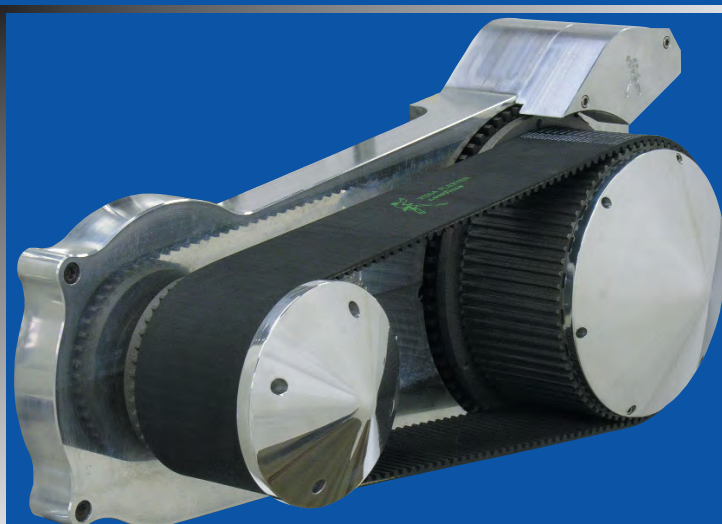

**16466 INTIMIDATOR 3.0"** primary belt drive with optional 40097 'Hubcap' front pulley cover and 40095 'Hubcap' rear pulley cover

Intimidator  
Primary  
Belt Drives

Outboard  
Bearing  
Supports

Piranha  
Clutches

Intimidator  
Motor Plates  
& Accessories

Enclosed &  
Open Primary  
Belt Drives

Rear Belt  
Drives

Replacement  
Primary &  
Rear Belts

Replacement  
Pulleys

Replacement  
Components

Terms &  
Conditions  
Of Sale



# INTIMIDATOR SERIES PRIMARY BELT DRIVES - PANHEAD, ELECTRIC START

## INTIMIDATOR SERIES

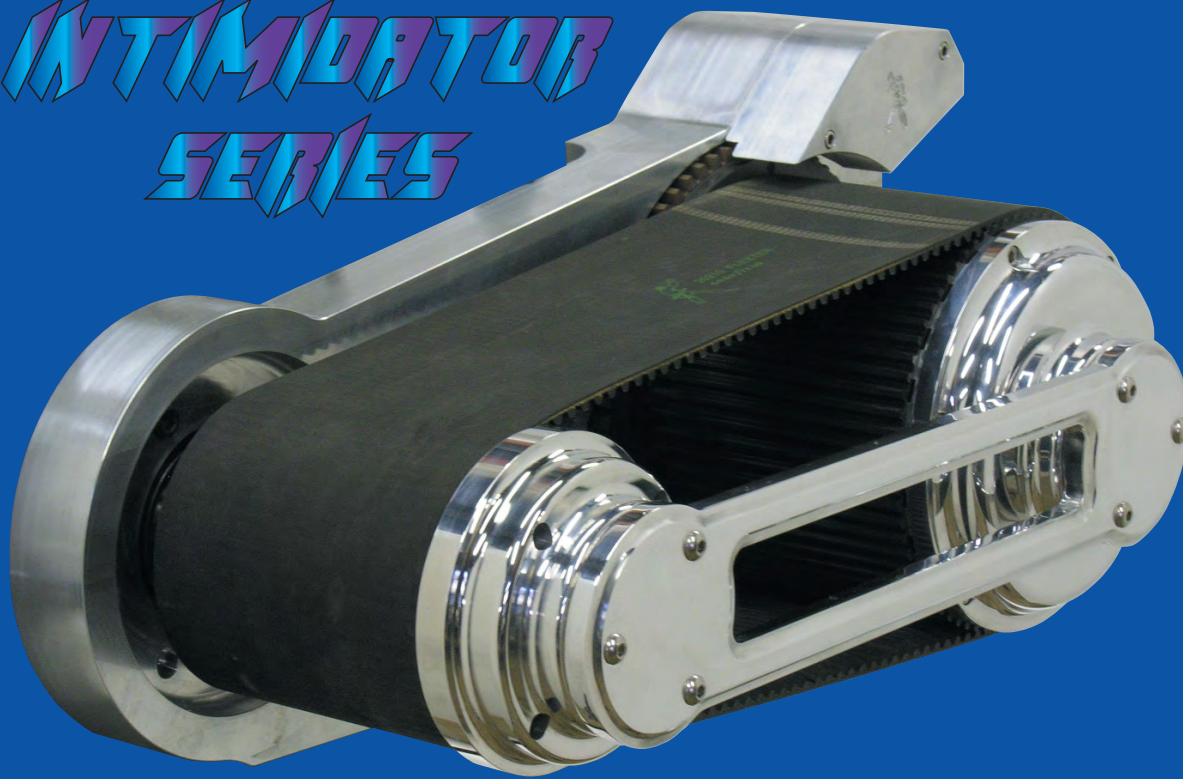

### PANHEAD, ELECTRIC START PRIMARY BELT DRIVES 3", 4", 5" WIDTHS

### LEFT-SIDE DRIVE - 4-SPEED & SOFTAIL 5-SPEED CONVERSION

#### CONVERT ANY 1955-1969 FX/FL 4-SPEED MODEL TO A SOFTAIL 5-SPEED

**KARATA'S INTIMIDATOR SERIES** primary belt drives are designed to work on Big Twin models from 1936 to present. Not just for Softails, **INTIMIDATOR SERIES** belt drives for Panhead and Shovelhead models offer a wide selection for upgrading classic 4-speed FX/FL models.

Available in three sizes, massive 5", beefy 4" and traditional 3", this innovative **INTIMIDATOR SERIES** primary belt drive converts any 1955-1969 FX/FL 4-speed with either a rigid frame or swingarm frame to accept a 1990-1999 Softail-style 5-speed transmission. This combination installs in the 4-speed swingarm frame with only a slight modification to the transmission case. Rigid frame applications require no modifications, but a Paughco transmission plate is necessary.

#### OPTIONS

**KARATA'S** outboard bearing support system can be used on all **INTIMIDATOR SERIES** belt drives that accept 1990-up transmissions.

The outboard bearing support system is included with all 5" **INTIMIDATOR SERIES** belt drives and is an ideal option for 3" and 4" drives.

See **Section 2** for complete details on outboard bearing support systems.

#### 1955-1969 FX/FL 4-SPEED MODELS WITH 4-SPEED OR AFTERMARKET 5-IN-4 TRANSMISSIONS

Any 1955-1969 FX/FL 4-speed swingarm model can be fitted with a **KARATA INTIMIDATOR SERIES** primary belt drive. These belt drives are available for motorcycles running either 1973-1978 Ratchet Top 4-speeds or 5-in-4 transmission conversions and are available in two sizes, beefy 4" and traditional 3".

#### CUSTOM OPTIONS FOR CUSTOM BIKES

**INTIMIDATOR SERIES** primary belt drives #16471 - 16477 are designed for custom motorcycles that use aftermarket 4-speed-style frames or rigid frames that use ratchet-top 4-speed transmissions. For 1990-1999 Softail transmission conversions, many aftermarket Softail and rigid frames can be used.

Regardless of which transmission option you choose, the **INTIMIDATOR SERIES** primary belt drives offer new options for custom motorcycle design.

Intimidator  
Primary  
Belt Drives

Outboard  
Bearing  
Supports

Piranha  
Klutches

Intimidator  
Motor Plates  
& Accessories

Enclosed &  
Open Primary  
Belt Drives

Rear Belt  
Drives

Replacement  
Primary &  
Rear Belts

Replacement  
Pulleys

Replacement  
Components

Terms &  
Conditions  
Of Sale

# INTIMIDATOR SERIES PRIMARY BELT DRIVES - PANHEAD, ELECTRIC START

## LEFT-SIDE DRIVE KITS

1955-1964 4-speed Panhead &  
1965-1969 4-speed Shovelhead  
FX/FL models with 1973-1978  
Ratchet Top 4-speed transmission

16471 3"  
16472 4"

1955-1964 4-speed Panhead &  
1965-1969 4-speed Shovelhead  
FX/FL models with aftermarket  
5-in-4 transmission

16473 3"  
16474 4"

1955-1964 4-speed Panhead &  
1965-1969 4-speed Shovelhead  
FX/FL models - Rigid frame  
Conversion to 1990-1999 Softail  
transmission

16475 3"  
16476 4"  
16477 5"

1955-1964 4-speed Panhead &  
1965-1969 4-speed Shovelhead  
FX/FL models - Swing arm frame  
Conversion to 1990-1999 Softail  
transmission

16478 3"  
16479 4"

**KARATA INTIMIDATOR SERIES** pri-  
mary belt drive kits 16475,  
16476, 16477, 16478, 16479 can  
be ordered with offset motor  
plates.

**SEE SECTION 4 FOR DETAILS**



16476 INTIMIDATOR 4.0" primary belt drive without front or rear pulley covers - See Section 4 for front pulley covers



16472 INTIMIDATOR 4.0" primary belt drive without front pulley cover - See Section 4 for front pulley covers

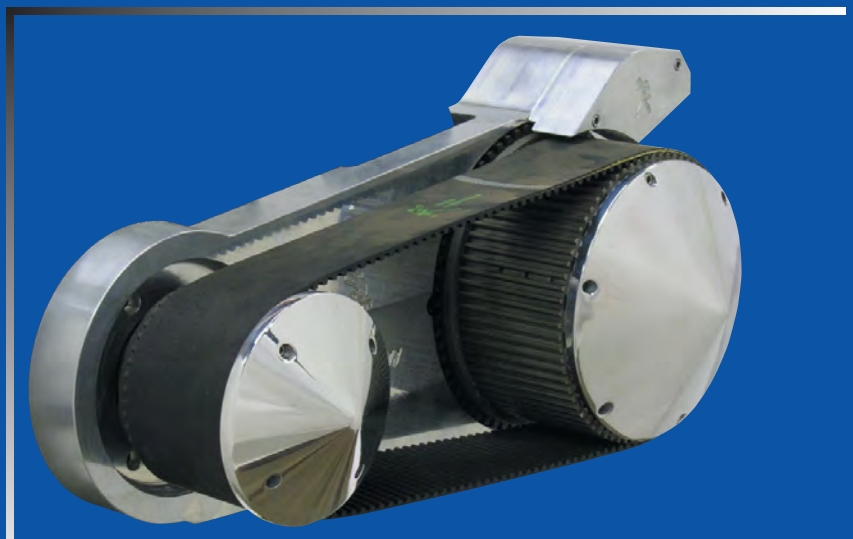

16471 INTIMIDATOR 3.0" primary belt drive with optional 40097 'Hubcap' front pulley cover and 40095 'Hubcap' rear pulley cover

Intimidator  
Primary  
Belt Drives

Outboard  
Bearing  
Supports

Piranha  
Clutches

Intimidator  
Motor Plates  
& Accessories

Enclosed &  
Open Primary  
Belt Drives

Rear Belt  
Drives

Replacement  
Primary &  
Rear Belts

Replacement  
Pulleys

Replacement  
Components

Terms &  
Conditions  
Of Sale



# INTIMIDATOR SERIES PRIMARY BELT DRIVES - KNUCKLEHEAD, ELECTRIC START

## INTIMIDATOR SERIES



### KNUCKLEHEAD, ELECTRIC START PRIMARY BELT DRIVES 3", 4" WIDTHS

### LEFT-SIDE DRIVE 4-SPEED, 5-IN-4 & SOFTAIL 5-SPEED CONVERSION

#### CONVERT ANY 1936-1954 FX/FL 4-SPEED MODEL TO A SOFTAIL 5-SPEED

**KARATA'S INTIMIDATOR SERIES** primary belt drives are designed to work on Big Twin models from 1936 to present. Not just for Softails, **INTIMIDATOR SERIES** belt drives for Knucklehead models offer a wide selection for customizing classic 4-speed FX/FL models.

Available in two sizes, beefy 4" and traditional 3", this innovative **INTIMIDATOR SERIES** primary belt drive converts any 1936-1954 FX/FL 4-speed with rigid frame to accept a 1990-1999 Softail-style 5-speed transmission. This combination installs in the 4-speed swingarm frame with only a slight modification to the transmission case. Rigid frame applications require no modifications, but a Paughco transmission plate is necessary.

#### OPTIONS

**KARATA'S** outboard bearing support system can be used on all **INTIMIDATOR SERIES** belt drives that accept 1990-up transmissions.

The outboard bearing support system is an ideal option for **INTIMIDATOR SERIES** 3" and 4" belt drives.

See **SECTION 2** for complete details on outboard bearing support systems.

#### 1936-1954 FX/FL 4-SPEED MODELS WITH 4-SPEED OR AFTERMARKET 5-IN-4 TRANSMISSIONS

Any 1936-1954 FX/FL 4-speed swingarm model can be fitted with a **KARATA INTIMIDATOR SERIES** primary belt drive. These belt drives are available for motorcycles running either 1973-1978 Ratchet Top 4-speeds or 5-in-4 transmission conversions and are available in two sizes, beefy 4" and traditional 3".

#### CUSTOM OPTIONS FOR CUSTOM BIKES

**INTIMIDATOR SERIES** primary belt drives #16480-16485 are designed for custom motorcycles that use aftermarket 4-speed-style frames or Rigid frames that use ratchet-top 4-speed transmissions. For 1990-1999 Softail transmission conversions, many aftermarket Softail and rigid frames can be used.

Regardless of which transmission option you choose, the **INTIMIDATOR SERIES** primary belt drives offer new options for custom motorcycle design.

Intimidator  
Primary  
Belt Drives

Outboard  
Bearing  
Supports

Piranha  
Klutches

Intimidator  
Motor Plates  
& Accessories

Enclosed &  
Open Primary  
Belt Drives

Rear Belt  
Drives

Replacement  
Primary &  
Rear Belts

Replacement  
Pulleys

Replacement  
Components

Terms &  
Conditions  
Of Sale

# INTIMIDATOR SERIES PRIMARY BELT DRIVES - KNUCKLEHEAD, ELECTRIC START

## LEFT-SIDE DRIVE KITS

1936-1954 4-speed Knucklehead  
FX/FL models with 1973-1978  
Ratchet Top 4-speed transmission

16480 3"  
16481 4"

1936-1954 4-speed Knucklehead  
FX/FL models with aftermarket  
5-in-4 transmission

16482 3"  
16483 4"

1936-1954 4-speed Knucklehead  
FX/FL models - Rigid frame  
Conversion to 1990-1999 Softail  
transmission

16484 3"  
16485 4"

**FROM  
1936  
TO  
PRESENT**

**KARATA**

Builds the widest selection  
of premium quality belt drives  
in the business!

Period.



16485 INTIMIDATOR 4.0" primary belt drive without front or rear pulley covers - See Section 4 for front pulley covers



16483 INTIMIDATOR 4.0" primary belt drive without front pulley covers - See Section 4 for front pulley covers

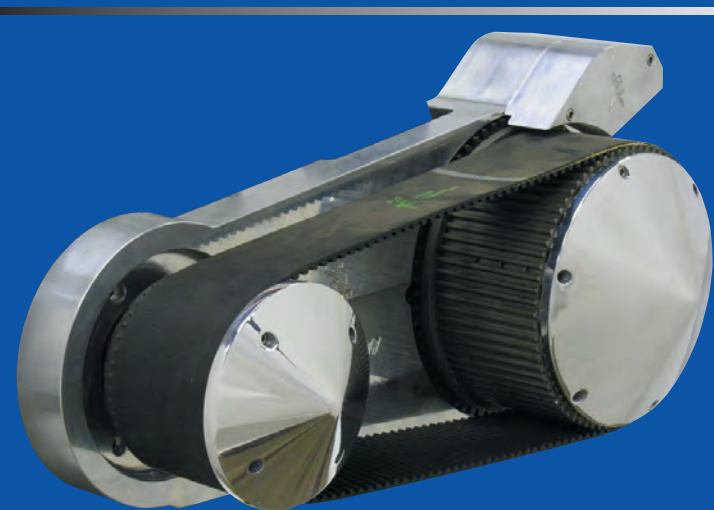

16480 INTIMIDATOR 3.0" primary belt drive with optional 40097 'Hubcap' front pulley cover and 40095 'Hubcap' rear pulley cover

Intimidator  
Primary  
Belt Drives

Outboard  
Bearing  
Supports

Piranha  
Clutches

Intimidator  
Motor Plates  
& Accessories

Enclosed &  
Open Primary  
Belt Drives

Rear Belt  
Drives

Replacement  
Primary &  
Rear Belts

Replacement  
Pulleys

Replacement  
Components

Terms &  
Conditions  
Of Sale



# INTIMIDATOR SERIES PRIMARY BELT DRIVES - KICK START

# INTIMIDATOR SERIES

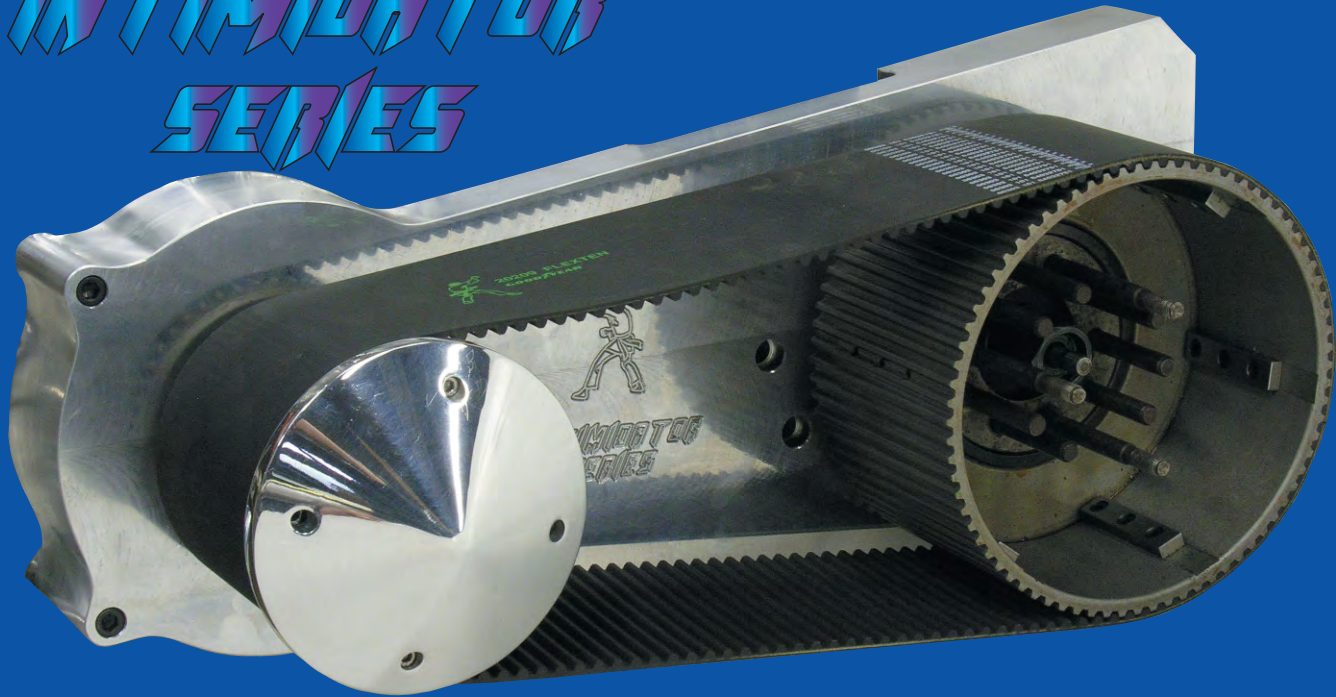

## PANHEAD, SHOVELHEAD, EVOLUTION KICK START PRIMARY BELT DRIVES, 3", 4", 5" WIDTHS LEFT-SIDE DRIVE 4-SPEED & 5-SPEED CONVERSION

### INTIMIDATOR SERIES KICK-START ONLY EARLY EVOLUTION FX, SHOVELHEAD & PANHEAD

Designed for motorcycles with kick-start **ONLY**. These **INTIMIDATOR SERIES** primary belt drives will work on Big Twin and Custom models from 1955-up with kick-start, and offer 3 transmission options.

### CONVERT ANY 1955-1969 FX/FL 4-SPEED MODEL TO A SOFTAIL 5-SPEED

Available in three sizes, massive 5", beefy 4" and traditional 3", this innovative **INTIMIDATOR SERIES** primary belt drive converts any 1955-1969 FX/FL 4-speed with rigid frame to accept a 1990-1999 Softail-style 5-speed transmission. This combination installs in the 4-speed swingarm frame with only a slight modification to the transmission case. Rigid frame applications require no modifications, but a Paughco transmission plate is necessary.

### OPTIONS

**KARATA'S** outboard bearing support system can be used on all **INTIMIDATOR SERIES** belt drives that accept 1990-up transmissions.

The outboard bearing support system is included with all 5" **INTIMIDATOR SERIES** belt drives and is an ideal option for 3" and 4" drives.

See **SECTION 2** for complete details on outboard bearing support systems.

### 1970-1984 & 1955-1969 FX/FL 4-SPEED MODELS WITH 4-SPEED OR AFTERMARKET 5-IN-4 TRANSMISSIONS

Any 1970-1984 FX/FL 4-speed swingarm model can be fitted with a **KARATA INTIMIDATOR SERIES** primary belt drive. These belt drives are available for motorcycles running either 1973-1978 Ratchet Top 4-speeds or 5-in-4 transmission conversions and are available in two sizes, beefy 4" and traditional 3".

### CUSTOM OPTIONS FOR CUSTOM BIKES

**INTIMIDATOR SERIES** primary belt drives #16489 - 16498 are designed for custom motorcycles that use aftermarket 4-speed-style frames or rigid frames that use ratchet-top 4-speed transmissions. For 1990-1999 Softail transmission conversions, many aftermarket Softail and rigid frames can be used.

Regardless of which transmission option you choose, the kick-start **INTIMIDATOR SERIES** primary belt drives offer new options for custom motorcycle design.

Intimidator  
Primary  
Belt Drives

Outboard  
Bearing  
Supports

Piranha  
Klutches

Intimidator  
Motor Plates  
& Accessories

Enclosed &  
Open Primary  
Belt Drives

Rear Belt  
Drives

Replacement  
Primary &  
Rear Belts

Replacement  
Pulleys

Replacement  
Components

Terms &  
Conditions  
Of Sale

# INTIMIDATOR SERIES PRIMARY BELT DRIVES - KICK START

## LEFT-SIDE DRIVE KITS

1970-up 4-speed FX/FL models  
Ratchet Top 4-speed transmission

16489 3"  
16490 4"

1970-up 4-speed FX/FL models  
Conversion to 1990-1999 Softail  
transmission

16491 3"  
16492 4"  
16493 5"

1955-1964 4-speed Panhead &  
1965-1969 4-speed Shovelhead  
FX/FL models with 1973-1978  
Ratchet Top 4-speed transmission

16494 3"  
16495 4"

1955-1964 4-speed Panhead &  
1965-1969 4-speed Shovelhead  
FX/FL models - Rigid frame  
Conversion to 1990-1999 Softail  
transmission

16496 3"  
16497 4"  
16498 5"



16490 INTIMIDATOR 4.0" primary belt drive without front pulley cover - See Section 4 for front pulley covers



16489 INTIMIDATOR 3.0" primary belt drive without front or rear pulley covers - See Section 4 for front pulley covers



16489 INTIMIDATOR 3.0" primary belt drive with optional 40097 'Hubcap' front pulley cover and 40095 'Hubcap' rear pulley cover

Intimidator  
Primary  
Belt Drives

Outboard  
Bearing  
Supports

Piranha  
Clutches

Intimidator  
Motor Plates  
& Accessories

Enclosed &  
Open Primary  
Belt Drives

Rear Belt  
Drives

Replacement  
Primary &  
Rear Belts

Replacement  
Pulleys

Replacement  
Components

Terms &  
Conditions  
Of Sale





# OUTBOARD BEARING SUPPORT SYSTEMS



# WHY USE AN OUTBOARD BEARING SUPPORT?

Intimidator  
Primary  
Belt Drives

Outboard  
Bearing  
Supports

Piranha  
Clutches

Intimidator  
Motor Plates  
& Accessories

Enclosed &  
Open Primary  
Belt Drives

Rear Belt  
Drives

Replacement  
Primary &  
Rear Belts

Replacement  
Pulleys

Replacement  
Components

Terms &  
Conditions  
Of Sale

Pulley alignment is absolutely crucial to proper performance and long life of ANY belt drive. When both pulleys are in alignment, the belt tracks straight, runs cool and performs optimally. ANY sort of pulley misalignment will shorten component life and potentially lead to disastrous results.

Ideally, the centerlines of both pulleys should be parallel to each other as shown in **Figure 1**. This condition allows the belt to run true, free of any binding or misalignment.



**FIGURE 1:** Ideal pulley alignment assures proper belt function and optimum performance.

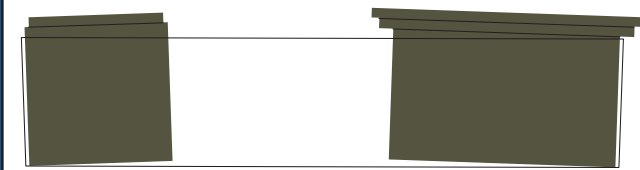

**FIGURE 2:** Improperly-aligned pulleys will cause belt and component failure

In cases of pulley misalignment, the pulleys can either point in toward each other as shown in **Figure 2**, or away from each other. Most common is the type of misalignment shown in Figure 2, but in either case it is easy to see how the belt will not run true and will either want to jump off the pulleys or track inward toward the engine. The result is the same in both cases, belt life is shortened

and the potential for component failure is likely. **KARATA INTIMIDATOR SERIES** belt drives are designed with massive billet aluminum motor plates that connect the engine and transmission together. Although the close-tolerance machining of each **INTIMIDATOR SERIES** motor plate ensures perfect alignment of the engine and transmission, there are many other factors that can cause problems.



Tolerances in frame construction, engine and transmission case machining and a host of other variables can all combine to create a cumulative error in pulley alignment. This is where the **KARATA** Outboard Bearing Support System does its magic.

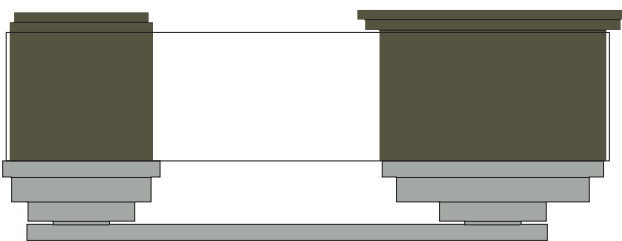

**FIGURE 3:** With a **KARATA** outboard bearing support system, the pulleys are locked in place with no movement possible.

Because all motorcycle models use specific center distances between the engine's sprocket shaft and the transmission's mainshaft, every **INTIMIDATOR SERIES** motor plate is machined to these specific dimensions. As shown in **Figure 3**, by adding outer bearing carriers to each pulley that are tied together with a support plate that has the exact same center distance as the motor plate, the pulleys are now locked in place and can **NEVER MOVE**.

Other manufacturers of outer bearing supports actually bolt their support plate to the motor plate, assuming that this adds further strength. In truth, this is not the case. Once the pulleys are secured with the outer support plate, they can never move. It is crucial to ensure that the center distance on the support plate matches the motor plate, and **KARATA'S** state-of-the-art CNC machining centers are accurate to within .0002". No other belt drive manufacturer can match the precision, quality and design innovation of **KARATA** and no other outboard bearing support works better and simpler.



# INSTALLATION AND FEATURES OF OUTBOARD BEARING SUPPORTS

**KARATA'S** outboard bearing support systems are sold as part of all 5" **INTIMIDATOR SERIES** primary belt drives. They are also offered as optional accessories for the 3" and 4" **INTIMIDATOR** belt drives and can be retrofitted to all 5-speed **INTIMIDATOR SERIES** belt drives ever made. Over 30 different support plates are available for both Softail-style and FXR/FLT-style platforms, in addition to several cover options.



Simple installation and ease of servicing were two of the key features designed into the **KARATA** Outboard Bearing Support System. Installation is literally as simple as removing the front pulley's guide plate and replacing it with the bearing carrier.



All **INTIMIDATOR SERIES** rear pulleys are manufactured with the correct hole pattern for the front and rear bearing carriers. However, some earlier-generation rear pulleys were tapped with different threads (10-32 instead of 1/4-20 which is now standard) and will require drilling and re-threading of these holes. **KARATA** includes the correct drill and tap in each outboard bearing support kit to allow the installer to make this modification quickly and easily.

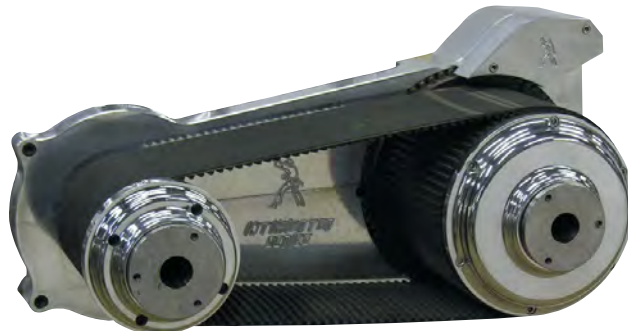

Once both bearing carriers are installed, the center support plate slips in place completing the installation. For future servicing, the outboard bearing support system can be removed in whole or part in a manner of minutes.



As with all **KARATA** belt drives, every component of the outboard bearing support system is available individually for servicing and rebuild.

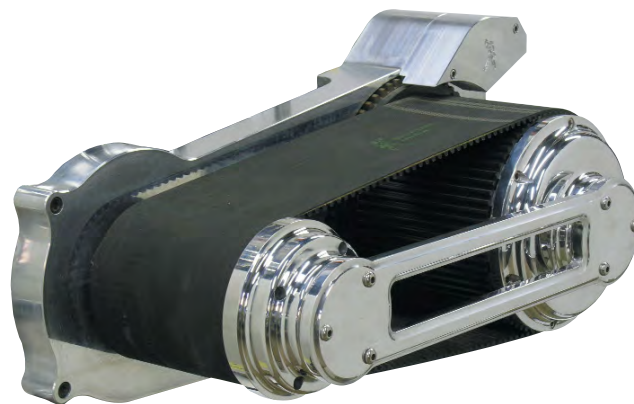

Intimidator  
Primary  
Belt Drives

Outboard  
Bearing  
Supports

Piranha  
Clutches

Intimidator  
Motor Plates  
& Accessories

Enclosed &  
Open Primary  
Belt Drives

Rear Belt  
Drives

Replacement  
Primary &  
Rear Belts

Replacement  
Pulleys

Replacement  
Components

Terms &  
Conditions  
Of Sale

# OUTBOARD BEARING SUPPORT SYSTEMS

Intimidator  
Primary  
Belt Drives

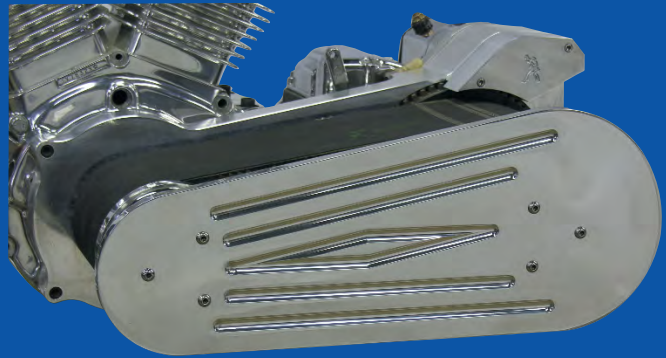

Softail/Dyna: 16110 kit 16110P plate only  
FXR/Road King: 16210 kit 16210P plate only

Softail/Dyna: 16115 kit 16115P plate only  
FXR/Road King: 16215 kit 16215P plate only

Outboard  
Bearing  
Supports

Piranha  
Klutch

Intimidator  
Motor Plates  
& Accessories

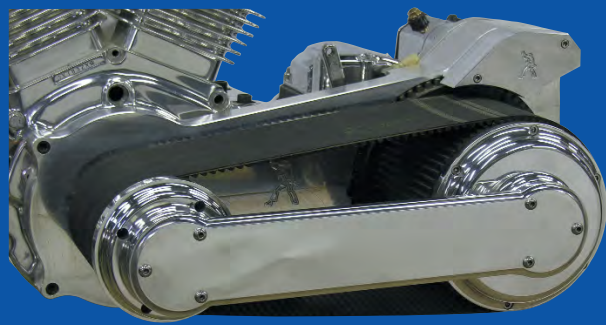
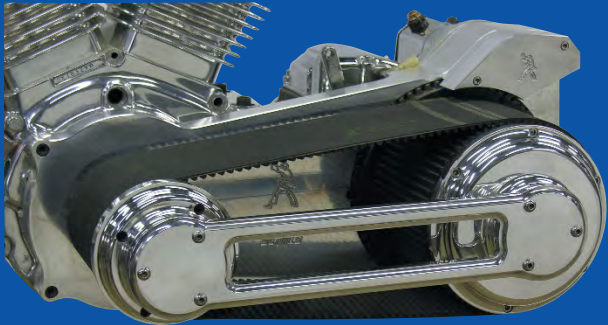

Softail/Dyna: 16120 kit 16120P plate only  
FXR/Road King: 16220 kit 16220P plate only

Softail/Dyna: 16121 kit 16121P plate only  
FXR/Road King: 16221 kit 16221P plate only  
Softail XCD: 16121XCD kit 16121XCDP plate only

Enclosed &  
Open Primary  
Belt Drives

Rear Belt  
Drives

Replacement  
Primary &  
Rear Belts

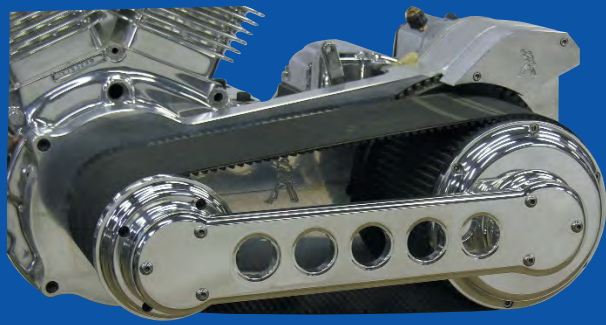
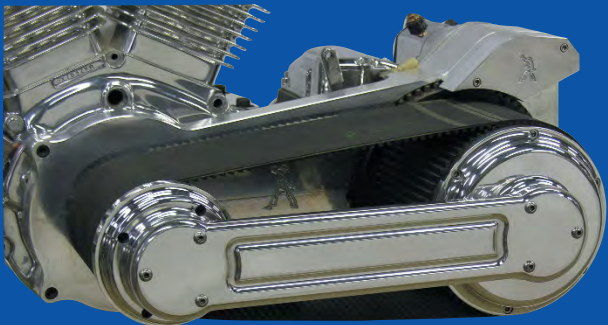

Softail/Dyna: 16122 kit 16122P plate only  
FXR/Road King: 16222 kit 16222P plate only

Softail/Dyna: 16123 kit 16123P plate only  
FXR/Road King: 16223 kit 16223P plate only  
Softail XCD: 16123XCD kit 16123XCDP plate only

Replacement  
Pulleys

Replacement  
Components

Terms &  
Conditions  
Of Sale

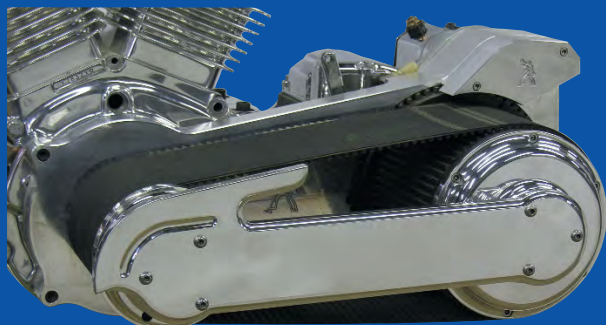

Softail/Dyna: 16125 kit 16125P plate only  
FXR/Road King: 16225 kit 16225P plate only

Softail/Dyna: 16126 kit 16126P plate only  
FXR/Road King: 16226 kit 16226P plate only





© 2006 Karata Enterprises, Co.  
All Rights Reserved  
Designed, Printed and Published in the U.S.A.